

Art.-Number: 703329

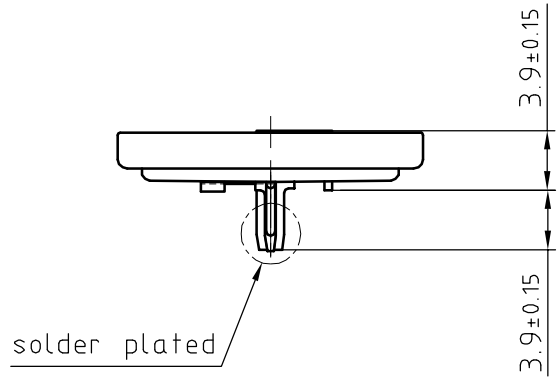
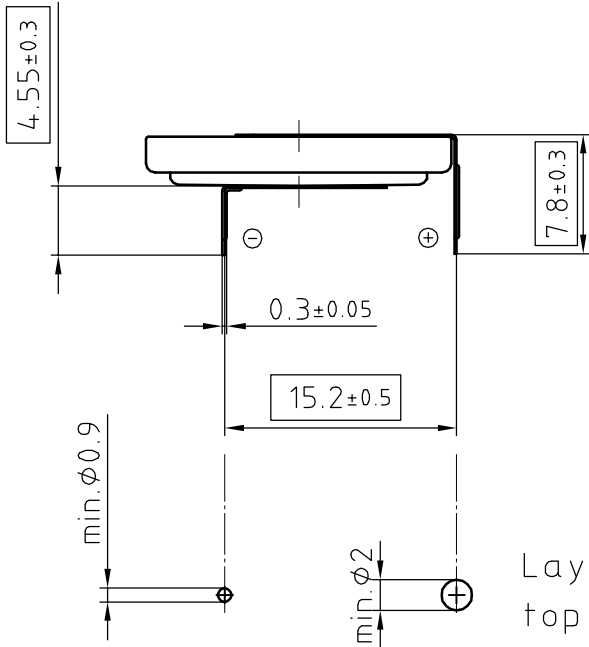
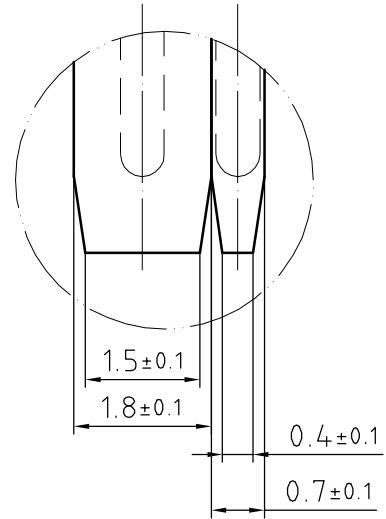
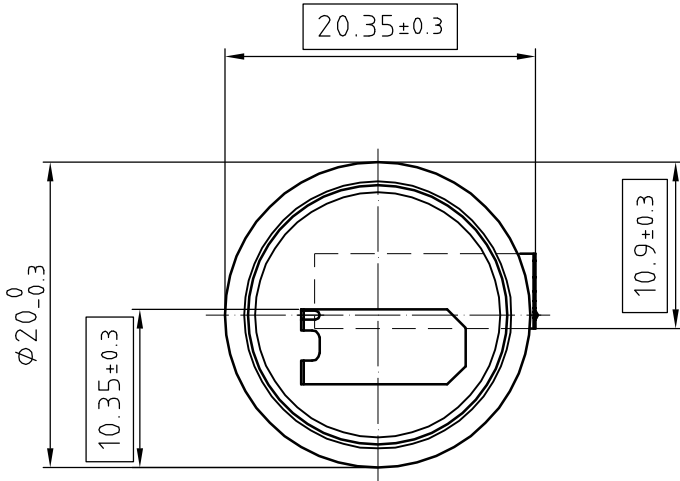

Layout top view

All dimensions in mm.

Tab material: Stainless steel

Direction of tab corrugation could be to the inner side, or outer side

All framed values will be used for dimension checking !

The Products of Renata SA are neither designed nor authorized for use in certain areas of application of environment.  
For further details we refer to our webpage [www.renata.com/downloads/restriction\\_of\\_use](http://www.renata.com/downloads/restriction_of_use)

Samples can deviate in the execution from the serie.

Dimensions and tolerances can be specified only after the testing of the devices for the mass production definitely

Rev.	①	23.08.19	PWu	Rev.	<input type="radio"/>				Customer's Approval				
Rev.	<input type="radio"/>			Rev.	<input type="radio"/>				Date				
Rev.	<input type="radio"/>			Rev.	<input type="radio"/>				Signature				
Title:								Scale 2:1	Drawn	18.09.12	PWu		
CR2032 MFR HF3									Checked				
									Approved				
								CH-4452 Itingen Switzerland			10.0919.4-1		