

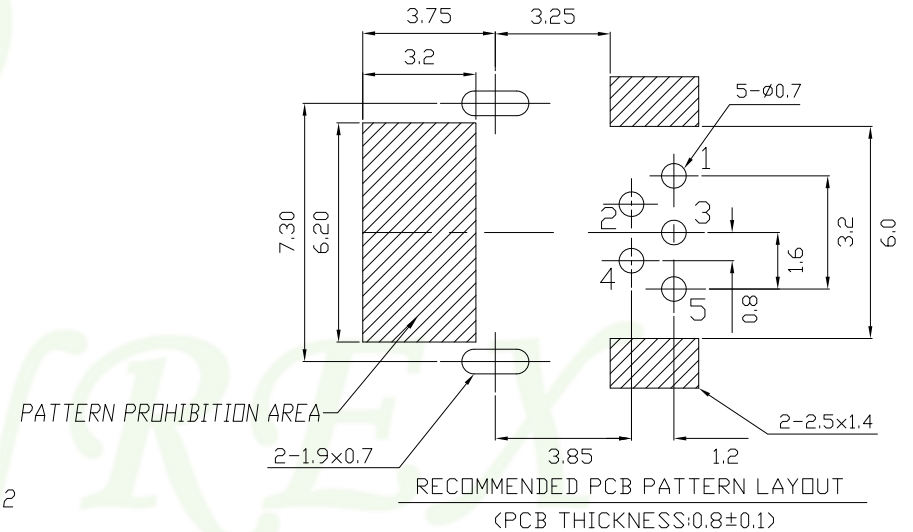

Specification:
 Contact Resistance: 50m Ohm. Max.
 Insulation Resistance: 100M Ohm Min. At 500VDC.
 Rated Voltage And Current: 1A At 30VAC Minimum.
 Dielectric Withstanding Voltage: 100V AC for 1 Minute
 Durability (Life Test): 1500 Cycles
 Insertion Force: 35 Newton Maximum.
 Extraction Force: 7 Newton Minimum.

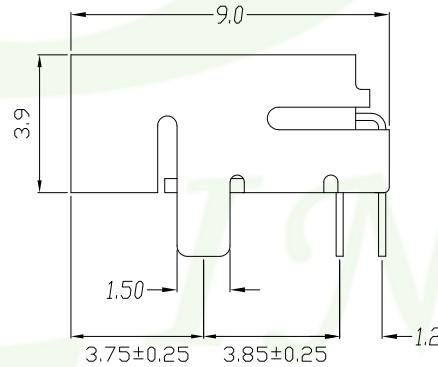
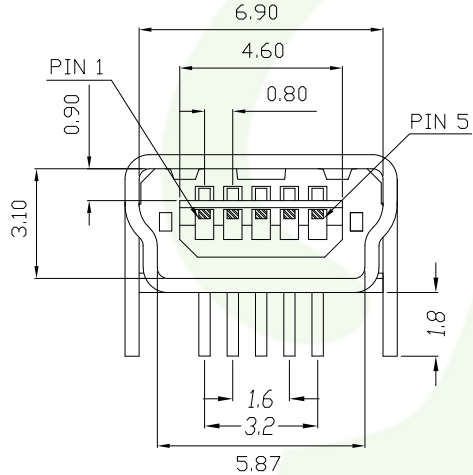

NO.	NAME	MATERIAL	FINISH	Q'TY	REMARK
1	HOUSING	NYLON PA9T G,F	BLACK	1	
2	PIN TERM.	PBS T:0.2	GOLD/TIN PLATED	5	Contact:Gold plating Solder area:Tin plated
3	SHELL	BRASS T:0.4	NICKEL PLATED	1	Ni:80~120u"
4	CENTER PASTERN	NYLON PA9T G,F	BLACK	1	

		TOLERANCE		UNITS : mm		OLD PART NO.		TITLE		 頻銳科技股份有限公司 PINREX TECHNOLOGY CORP.	
		.0 =±.30		DRAWER 劉偉晉		CHECK 李劍		USB MINI B 5Pin DIP			
		.00 =±.20		SCALE NONE		SIZE A4		Green Product			
A		.0000=±.0000		SHEET 1 OF 1		REV. A		NEW PART NO.		DRAW NO.	
REV.		DESCRIPTION		DATE		APP'D 李劍		984-3x-6051xx		984-3x-6051xx(網頁專用圖)	