

**RoHS**  
Compatible

△				
△				
△				
△				
ZONE	REV	DESCRIPTION	DATE	APPD.

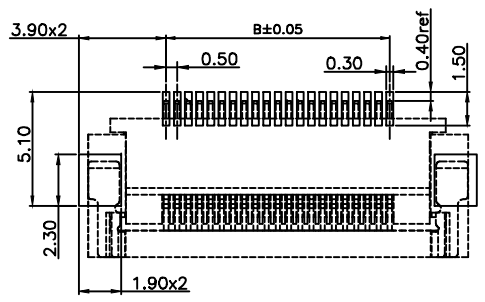
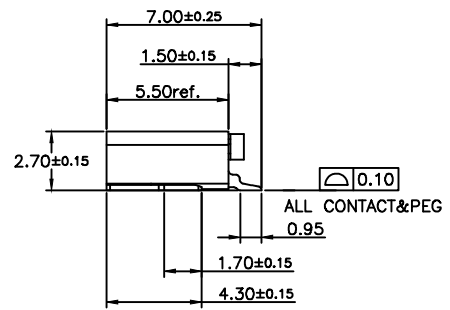
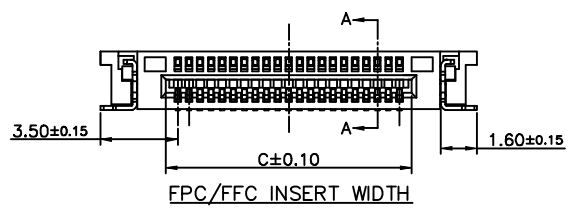
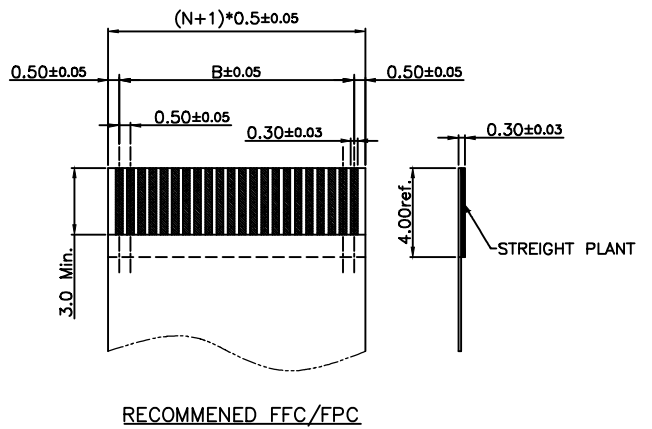
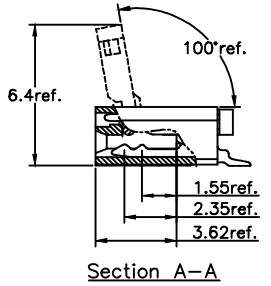
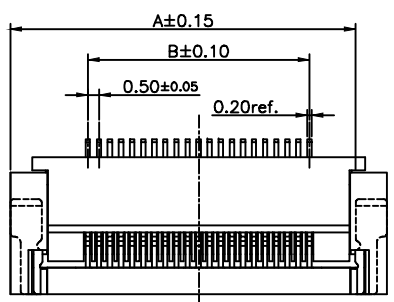

Order information :  
FP0507H-XXX X X X  
1 2 3 4 5

- With "H" : Halogen free
- Pin No.
- Packing :  
0 = Tape & Reel  
1 = Tube
- Plating spec :  
M = MATTE Sn  
G = Gold flash  
0 = Gold flash on contact area and Matte Sn solder area
- Color :  
0 = Housing(Nature)+Cover(Black)

**Specifications**

- Current Rating : 0.5A AC/DC
- Voltage Rating : 50V AC/DC
- Operating temperature : -45°C~+85°C

N = 051	A = 32.20	B = 25.00	C = 26.10
N = 041	A = 27.20	B = 20.00	C = 21.10
N	A = B+7.20	B = (N-1)*0.50	C = B+1.10
PIN NO.	DIM. A	DIM. B	DIM. C

4	Peg	Copper alloy	1	_____
3	Contact	Copper alloy	1	_____
2	Cover	High-temp	1	UL94 V-0
1	Housing	High-temp	1	UL94 V-0
No.	Part Name	Material	Qty	Finishing

**達立科技股份有限公司**  
**Dawning Precision Co., Ltd.**  
TEL: 886-2-82271388 FAX: 886-2-82272198

DESIGN	Eason	SCALE		
DRAWING	Eason	UNIT	mm	
CHECK	Eason	SIZE	A4: 210*297	
APPROVAL	Honda	VERSION	01	

TOLERANCE UNLESS OTHERWISE STATED(mm)	PART NAME	FPC 0.5mm Pitch 2.7H
0 _____ ±0.35	PART NO	FP0507H Series
0.0 _____ ±0.25	DRAWING NO	
0.00 _____ ±0.15	DATE	2020.02.26
ANGLE _____ ±3°		