

MotionPak[®]

MEMS Quartz Multi-Axis Inertial Sensing System

Ideal for Instrumentation and Industrial Applications:

- Vehicle Instrumentation
- Robotics
- Automotive Testing
- Attitude Reference Systems
- Control Systems
- Dead Reckoning Aiding GPS
- Flight Testing
- Buoy Instrumentation
- Platform Stabilization



Key Performance Features:

- **Solid State Sensors**
- **Compact, Rugged Package**
- **Long Operating Life**
- **Low Cost**
- **High Level Analog Outputs**
- **Wide Bandwidth**
- **Fast Start-Up**
- **Fully Self-Contained System**
- **Customized Axis Configurations**



The MotionPak[®] is a solid-state sensor cluster used for measuring linear accelerations and angular rates in instrumentation and control applications. It is a highly reliable, compact, and fully self-contained motion measurement package with analog voltage outputs. It uses three orthogonally mounted solid-state, micro-machined quartz angular rate sensors, and three high-performance linear servo accelerometers mounted in a compact, rugged package, with internal power regulation and signal conditioning electronics. The MotionPak[®] is available in a wide range of custom configurations to suit your application's requirements.

www.emcore.com/nav

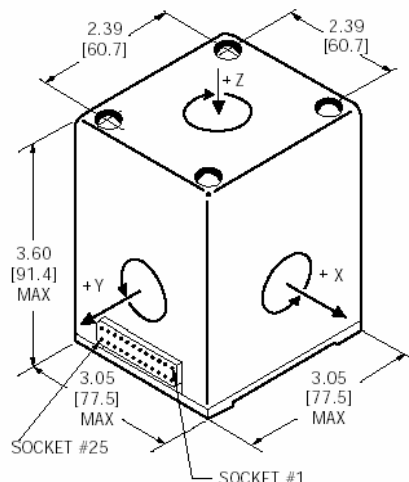

	Rate Channels	Acceleration Channels
Power Requirements		
Input Voltage	+ and – 15 Vdc ±10%	
Input Current	<270mA (each supply)	
Performance		
Standard Range**	±100°/sec	±1,2,3,5,10,g's
Full Scale Output (Nominal)	±2.5 Vdc	±7.5 Vdc
Scale Factor Calibration (at 22°C)	≤1% of value	
Scale Factor, Temperature Sensitivity	<0.03%/°C	
Long Term Scale Factor Stability (1 year)	10000 ppm	<1700 ppm
Bias Factory Set	≤2.0°/sec*	<±8 mg
Bias Variation over Temperature (Max Deviation from 22°C)	≤2°/sec from 22°C*	≤70 µg/°C
Long Term Bias Stability (1 year)	<0.2°/sec*	<1200 µg
G Sensitivity	≤0.02°/sec/g	-
Start-Up Time	1.0 sec	
Bandwidth (-90°)	>60 Hz	>300 Hz
Non-Linearity	≤0.05% F.R.	-
Threshold/Resolution	≤0.004°/sec*	≤10 µg
Output Noise (DC to 100 Hz)	≤0.01°/sec/√Hz*	≤7.0 mV
Environments		
Operating Temperature	-40°C to +80°C	
Storage Temperature	-55°C to +100°C	
Vibration Survival***	10g rms 20 Hz to 2 kHz random, 5 hour duration	
Shock	200 g	
Weight	900 grams	

* Values indicated are for ±100°/sec range.

** Other acceleration and rate ranges are available – consult factory.

*** Please see user's guide for more information regarding vibration tolerance and sensitivity.

Other Information

1. Part number based on ranges, options and number of channels specified
2. Rate channel options – High Performance, Low Noise, Wide Bandwidth, Special Ranges
3. Acceleration Channel Option – Current output

For more information, contact:

EMCORE Corporation
2015 Chestnut Street
Alhambra, CA 91803 USA
Tel: +1 626.293.3700

www.emcore.com/nav

emcore[®]