



Product Specification

XL100 Series

100 Watt Power Supplies

Document No. 703596 Rev 07-01-19

Notices

N2Power™ - a subsidiary of Qualstar Corporation.

N2Power and the *N2Power* logo are registered trademarks of Qualstar Corporation.

Copyright© 2018 by Qualstar Corporation — All Rights Reserved

For warranty information refer to www.n2power.com

Information contained in this document is copyrighted by Qualstar Corporation and is intended for use by customers and prospective customers to evaluate and integrate our power supplies. Customers and prospective customers may reproduce this document as needed for these purposes. Reproduction in whole or in part for any other purpose or by any other party is prohibited without prior written permission from Qualstar Corporation.

Every effort has been made to keep the information contained in this document current and accurate as of the date of publication or revision. However, no guarantee is given or implied that the document is error-free or that it is accurate with regard to any specification. *N2Power* reserves the right to modify the design or specification without notice.

This specification may not be construed as a contractual obligation except as specifically agreed to by *N2Power* in writing at the time of order.

For information about this product specification, please write or call *N2Power* at:

N2Power

Subsidiary of Qualstar Corp.
1267 Flynn Road
Camarillo, CA 93012

FAX: (805) 978-5212
Phone: (805) 583-7744

E-Mail: sales@n2power.com
www.n2power.com

Table of Contents

1.	Introduction	1-1
1.1	Introduction	1-1
1.2	Agency Compliance	1-2
2.	AC Input.....	2-1
2.1	Input Line Requirements.....	2-1
2.2	Input Over-Current Protection	2-1
2.3	Inrush Current Limiting	2-1
2.4	Low Input Voltage	2-1
2.5	Leakage Current.....	2-1
3.	DC Outputs.....	3-1
3.1	Output Voltage Regulation	3-1
3.2	No Load Operation	3-1
3.3	Output Current/Power	3-1
3.4	Output Ripple/Noise	3-3
3.5	Local and Remote Sensing	3-Error! Bookmark not defined.
3.6	Output Rise Time	3-4
3.7	Overshoot At Turn On/Turn Off	3-4
4.	General Specifications.....	4-1
4.1	Environmental	4-1
4.2	Mean Time Between Failures	4-1
4.3	Labeling/Marking.....	4-1
4.4	Net Weight.....	4-2
4.5	Mounting.....	4-2
4.6	Mating Connectors	4-2
4.7	Output Grounding	4-2
4.8	Physical Dimensions	4-3
5.	Efficiency	5-1
6.	Signals.....	6-1
6.1	Power Good Signal/PS_OK Signal/	6-1
6.2	Voltage Hold-Up Time	6-1
7.	Ordering Information	7-1

1. Introduction

1.1 Introduction

This specification defines the XL100 series of 100W Open-Frame, U-Frame, Enclosed and DIN Rail type universal input switching mode power supplies. It includes information regarding the mechanical details, cooling requirements, connector configurations, electrical and signal specifications, and environmental ranges for storage and operation of the power supplies. These supplies achieve very high packaging densities and low air cooling requirements by virtue of their very high efficiency design.

N2Power Model numbers for this series of power supplies begin with:

- XLO for Open-Frame models
- XLU for U-Frame models
- XLE for Enclosed models
- XLD for DIN Rail models

However, except where it is necessary to distinguish them, the series is referred to as XL100 throughout this Specification.



Figure 1-1 XL100 Open-Frame, U-Frame, Enclosed and DIN Rail Power Supplies

1.2 Agency Compliance





Safety	Complies with Standard	Remarks
United States/Canada	UL 60950-1	
EU Council	EN 60950-1	
International	IEC 60950-1	
EMC	Complies with Standard	Remarks
Emission	EN 55011, EN55032 & FCC Part 15	Conducted Emission Class B Radiated Emission Class A
	IEC 61000-3-2	Harmonic Current Emissions
	IEC 61000-3-3	Voltage Fluctuations & Flicker
Immunity	EN55024	Electromagnetic Sensitivity
	EN 61000-4-2	Electrostatic Discharge
	EN 61000-4-3	Radiated Susceptibility
	EN 61000-4-4	Fast Transient/Burst Immunity
	EN 61000-4-5	Power Mains Surge Immunity
	EN 61000-4-6	Conducted Susceptibility
	EN 61000-4-8	Power Frequency Magnetic Field
	EN 61000-4-11	Voltage Dips, Short Interruptions
Reduction of Hazardous Substances (RoHS)	Complies with Standard	Remarks
EU Council	2011/65/EU RoHS 2 Directive	RoHS 2 Directive
Marks of Conformance		
United States/Canada		
		
EU Council		
RoHS		

Table 1-1 Agency Compliance

2. AC Input

2.1 Input Line Requirements

The following table defines the voltage and frequency requirements for the AC line inputs to the XL100 Series which is capable of supplying full rated power in continuous operation throughout the specified ranges of voltages and frequencies. The power supply will automatically recover from AC power loss and is capable of starting under maximum load at the minimum AC input voltage described below.

Parameter	Minimum	Maximum
Input Voltage (AC)	85VAC	264VAC
(DC)	120VDC	370VDC
Input Current		1.15A/115VAC 0.55A/230VAC
Input Frequency (AC)	47 Hz	63 Hz

Table 2-1 XL100 Series AC Input Parameters

2.2 Input Over-Current Protection

The XL100 Series incorporates a primary AC line fuse (3.15A/250VAC) for input over-current protection to prevent damage to the power supply and meet product safety requirements as outlined in Section 1.2.

2.3 Inrush Current Limiting

The cold start inrush current for the XL100 Series is 100A maximum at 230VAC.

Repetitive ON/OFF cycling of the AC input voltage shall not damage the power supply or cause the input fuse to fail.

2.4 Low Input Voltage

The application of an input voltage below the minimums specified in Table 2-1 shall not cause damage to the power supply.

2.5 Leakage Current

The leakage current between the protective ground of any XL100 Series power supply and actual ground when the unit is operating at maximum input voltage (264VAC), is less than or equal to 300 μ A.

3. DC Outputs

3.1 Output Voltage Regulation

The DC output voltages shall remain within the Minimum and Maximum limits of Table 3-1 when measured at the power supply connector under all specified line, load and environmental conditions contained herein.

Model	Output	Rated Voltage	Regulation	Minimum (VDC)	Maximum (VDC)
XL100-12	V1	12	±1.7%	11.880	12.120
XL100-15	V1	15	±1.7%	14.850	15.150
XL100-24	V1	24	±1.7%	23.760	24.240
XL100-28	V1	28	±1.7%	27.720	28.280
XL100-36	V1	36	±1.7%	35.640	36.360
XL100-48	V1	48	±1.7%	47.520	48.480

Table 3-1 XL100 Output Voltage Specifications

3.2 No Load Operation

The power supply can operate under a no load condition without any damage. The power supply will remain stable and operate normally after application of loads.

CAUTION

Remove AC power prior to installing or removing secondary loads.

3.3 Output Current/Power

The maximum available output power is always a function of the cooling airflow and temperature.

3.3.1 Output Loading

The output currents listed below require natural convection cooling at no more than 50°C.

Model	Rated V1 Output	Output Current (convection cooling)
XL100-12	12V	8.34A
XL100-15	15V	6.67A
XL100-24	24V	4.17A
XL100-28	28V	3.58A
XL100-36	36V	2.78A
XL100-48	48V	2.09A

Table 3-2 Output Currents

3.3.2 High Temperature Derating

The XL100 Series can be operated at elevated temperatures by derating the total maximum output power (or current) by 2%/°C from 50°C to 85°C (see Figure 3-1).

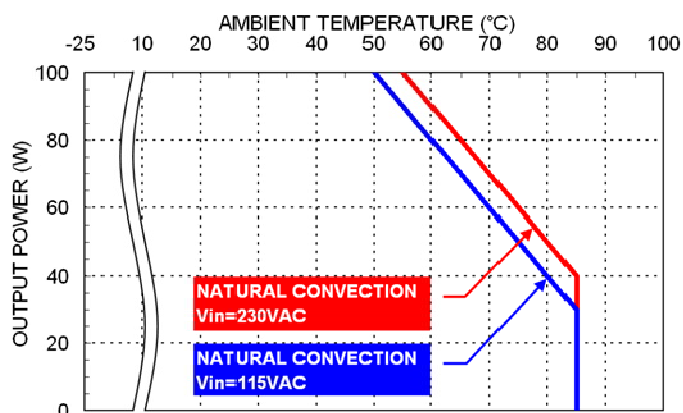

Derating Curve vs. Ambient Temperature
XLO100 and XLU100

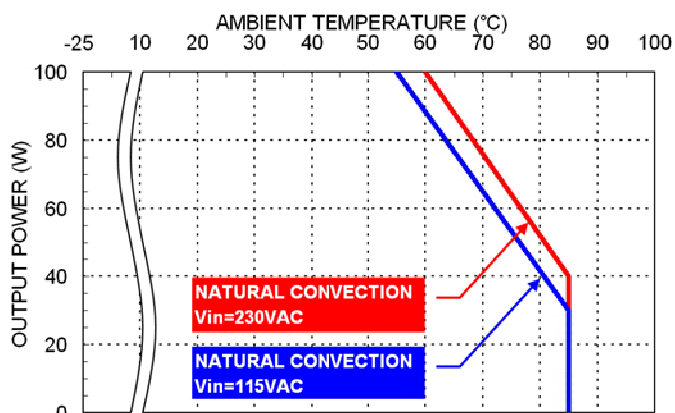

Derating Curve vs. Ambient Temperature
XLE100 and XLD100

Figure 3-1 Derating Curves: XL100 Series

3.3.3 Input Voltage Derating

The XL100 Series can be operated at the minimum input voltage of 85VAC with the maximum load of 80% of the total maximum output power. From 90VAC to 100VAC, the output load can be increased by 1%/VAC.

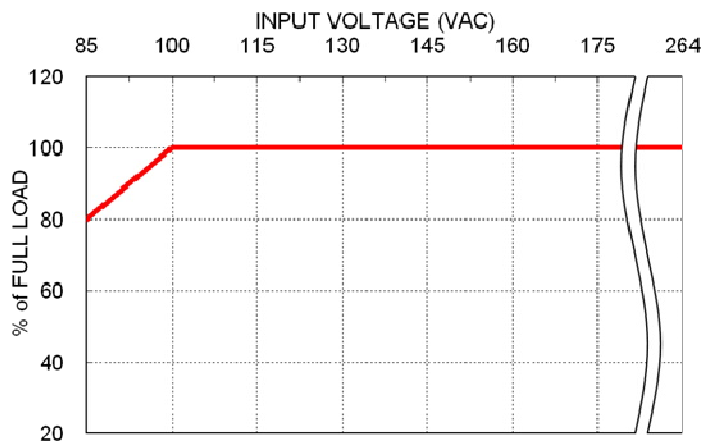

Figure 3-2 Load vs. Input Voltage

3.3.4 Low Temperature Derating

At an ambient temperature of -40°C, the XL100 series can deliver 80% of rated load with the input voltage at 100VAC, increasing to 100% with 200VAC input. From 200VAC onwards, the power supply can deliver the full 100% of rated load.

3.4 Output Ripple/Noise

Output ripple voltage and noise are measured at 20MHz of bandwidth by using a 12" twisted pair wire terminated with a ceramic capacitor (MLCC) in parallel with the load. The capacitance value of this MLCC is 10 μ F for 12V and 15V models, 1 μ F for 24V, 28V and 36V models, and 0.1 μ F for the 48V model. The ripple noise is measured from the output pin connectors.

3.4.1 Ripple/Noise Limits

Ripple and noise shall not exceed the limits specified in Table 3-3 under any condition of line voltage and frequency specified in Section 2.1 and DC loading specified in Section 3.3.1.

Model	Output	Voltage	Maximum Ripple + Noise (peak-to-peak)
XL100-12	V1	12V	120mV
XL100-15	V1	15V	150mV
XL100-24	V1	24V	160mV
XL100-28	V1	28V	180mV
XL100-36	V1	36V	190mV
XL100-48	V1	48V	340mV

Table 3-3 Ripple Voltage

3.4.2 Ripple/Noise Test Setup

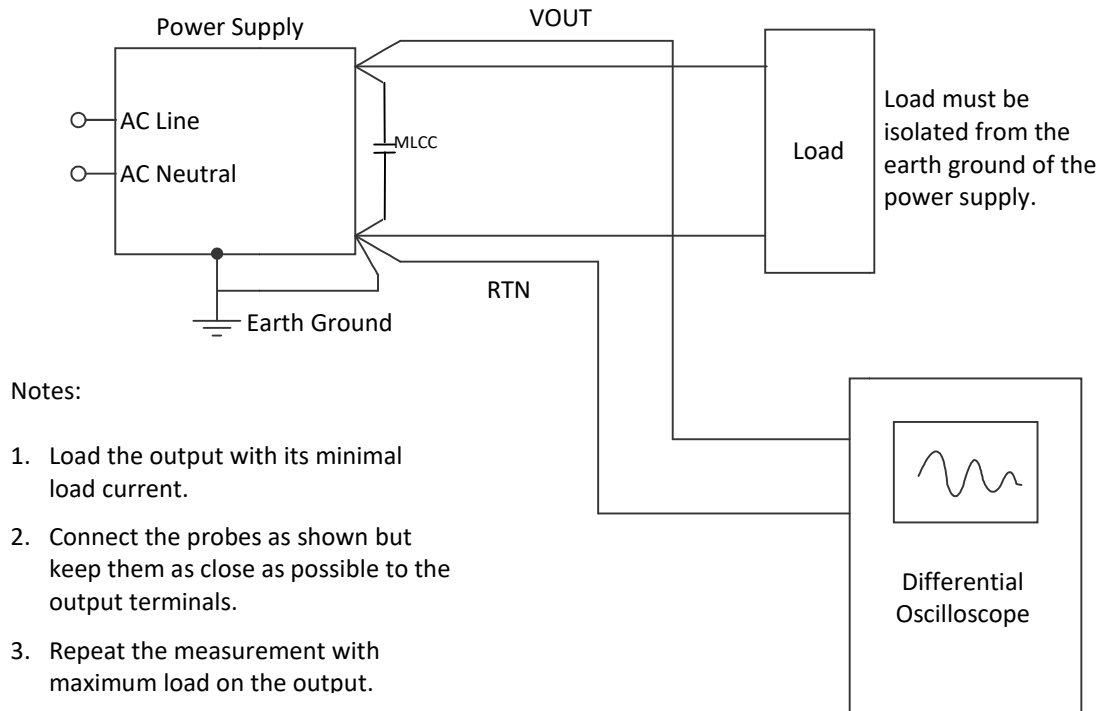

Figure 3-3 Ripple Noise Measurement Setup

3.4.3 Over Voltage Protection

No single fault is able to cause a sustained over voltage condition on any output. When an over-voltage condition occurs, the power supply will shut down and will not restart until AC power is turned off and back on. The XL100 Series will shut down under the following over voltage conditions:

Model	Minimum	Nominal	Maximum
XL100-12	13.80V	15.00V	16.20V
XL100-15	17.25V	18.75V	20.25V
XL100-24	27.60V	30.00V	32.40V
XL100-28	32.20V	35.00V	37.80V
XL100-36	41.40V	45.00V	48.60V
XL100-48	55.20V	60.00V	64.80V

Table 3-4 Over-Voltage Protection Limits

3.4.4 Short Circuit Protection

A short circuit is defined as an impedance of less than 0.1 ohms placed between DC RETURN and any output. A short circuit will cause no damage to the power supply and will cause it to shutdown. The power supply will periodically attempt a restart until the short circuit condition is removed. After successfully restarting, the power supply will operate normally.

3.5 Output Rise Time

All output voltages shall rise from 10% to 90% of rated output voltage (as specified in Table 3-1) within 20mS. The output voltages waveform must be a monotonic ramp from 10% to 90% of final setpoint within the regulation band under any loading conditions as specified in Section 6.

For the purposes of this specification, a monotonic ramp is defined as always having a positive slope of from zero to $10 \times V_{out}$ volts/millisecond. During any 5-millisecond portion of the ramp, its slope must be greater than 5% of its rated voltage per millisecond.

3.6 Overshoot At Turn On/Turn Off

The output voltage overshoot upon the application or removal of the input mains voltage is less than 5% for all XL100 models above the nominal voltage. No opposite polarity voltage is present on any output during turn on or turn off.

3.7 Voltage Trim

A potentiometer (see Figure 3-4) is provided to allow the user to adjust the V1 output up or down by up to 10%. The ability of the V1 output to maintain its specified regulation accuracy under severe load or line conditions could be diminished by trimming the output to a higher than nominal voltage. The load current and power should not exceed the maximum limits described in Section **Error! Reference source not found.**

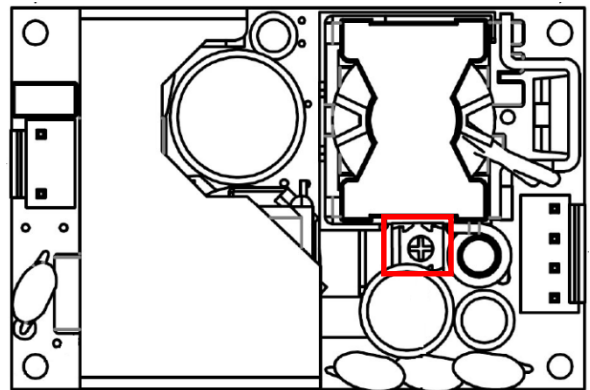

Figure 3-4 Potentiometer for V1 Output Adjustment

4. General Specifications

4.1 Environmental

The XL100 Series meets or exceeds the following environmental specifications:

Parameter	Conditions	Specification	Remarks
Temperature	Operating	-40°C to 85°C	
	Non-Operating	-40°C to 85°C	
Relative Humidity	Operating	95% Maximum	Non-Condensing
	Non-Operating	95% Maximum	Non-Condensing
Altitude	Operating	16,404 feet MSL Max.	5,000 meters
Shock	No damage	Meets IEC60068-2-27	
Vibration	No damage	Meets IEC60068-2-6	

Table 4-1 Environmental Specifications

4.2 Mean Time Between Failures

The calculated MTBF of the XL100 is 790,000 hours, which is equal to or greater than the specified hours of continuous operation at maximum output loading and worst-case input line voltage with convection cooling at 25°C. N2Power does not warrant the MTBF to be representative of any particular unit. The MTBF of the power supply is calculated with an 80% confidence level in accordance with (MIL-HDBK-217F). Actual failure rates vary from unit to unit.

4.3 Labeling/Marking

The power supply is marked and labeled with the N2Power logo and part number, model number, input and output specifications, production code, appropriate safety agency logos and CE mark.

A typical label is pictured below.



Figure 4-1 Sample XL100 Label

4.4 Net Weight

Model	Weight (grams)	Weight (ounces)
XLO100	156	5.50
XLU100	194	6.84
XLE100	210	7.41
XLD100	232	8.18

4.5 Mounting

The XL100 Series units are mounted with screws at the mounting holes at the corners. The diameter of the mounting holes is 3.2 mm (0.125 in.)

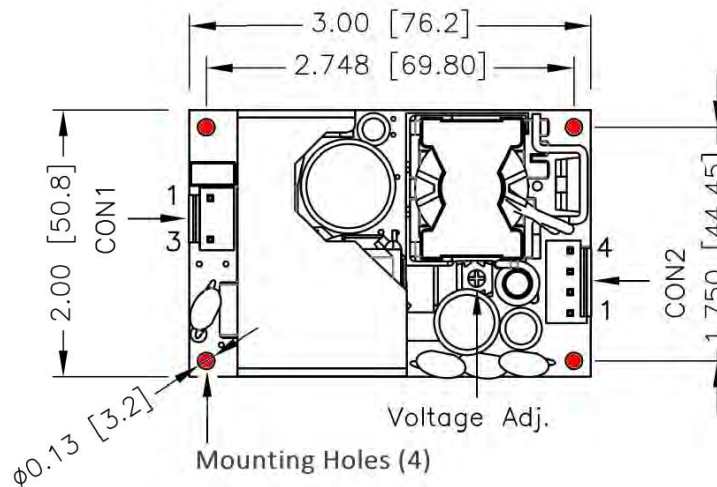

Figure 4-2 XL100 Mounting Hole Locations

4.6 Mating Connectors

The user must furnish all mating connectors. The mating connectors must meet the requirements of all applicable safety agencies (UL and/or TUV).

Model	Designator	Connector	Mating Housing	Terminal
XL100	CN1 (AC Input)	JST B3P-VH or equivalent	JST VHR-3N or equivalent	JST SVH-21T-P1.1 or equivalent
	CN2 (DC Output)	JST B4P-VH or equivalent	JST VHR-4N or equivalent	JST SVH-21T-P1.1 or equivalent

Table 4-2 XL100 Mating Connectors

4.7 Output Grounding

The DC RETURN signal may be connected to the power supply chassis ground (safety earth) at the plated through mounting hole(s) shown in red in Figure 4-2.

4.8 Physical Dimensions

Open-Frame Type

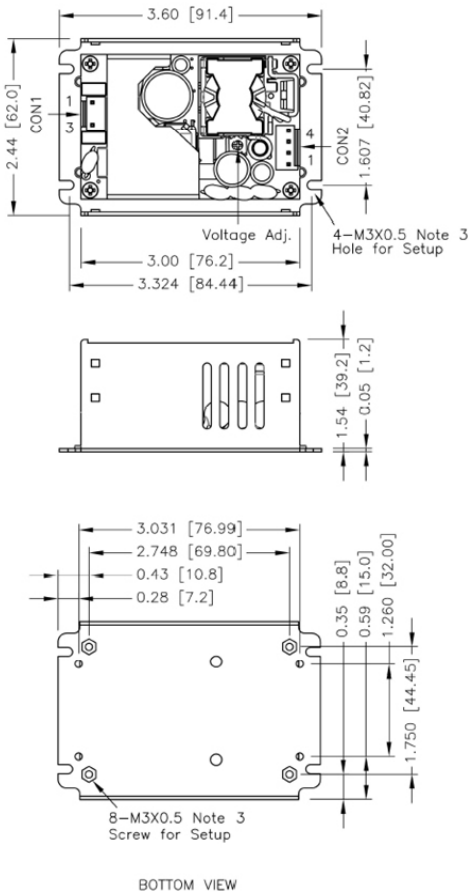
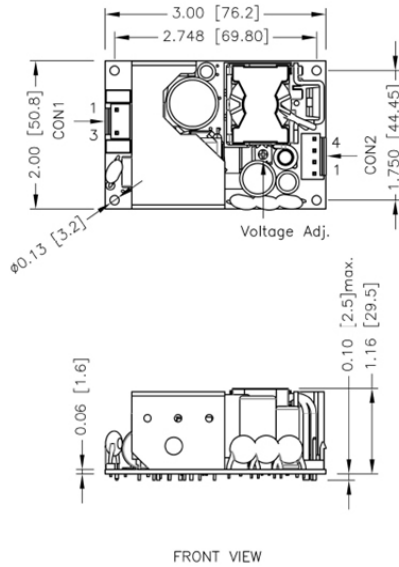

DIN Rail Type

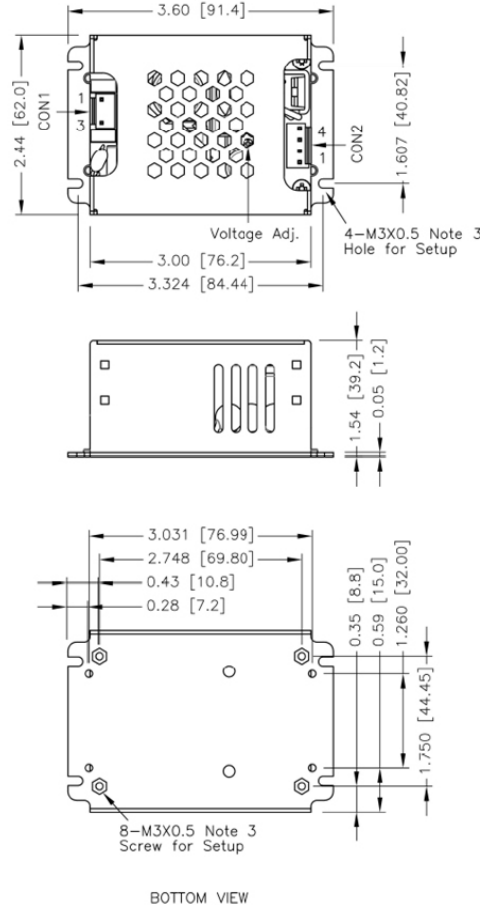
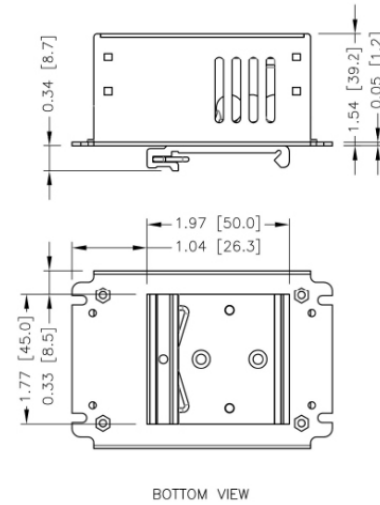

Connector Pin Assignments

CON1 – Input Connector	
Pin 1	Line
Pin 3	Neutral

CON2 – Output Connector	
Pin 1, 2	- V _{out}
Pin 3, 4	+ V _{out}

Notes

1. All dimensions are in inches [mm]
2. Tolerance: $x.xx \pm 0.02$ ($x.x \pm 0.5$)
 $x.xxx \pm 0.01$ ($x.xx \pm 0.25$)
3. M3x0.5 screw locked torque MAX 5Kgf.cm/0.49N.m
4. Any one of the four screw holes of the Open Frame chassis can be used as a PG connection point for CLASS I application.

Figure 4-3 Mechanical Drawings (All Models)

5. Efficiency

The efficiencies for XL100 power supplies are listed below. They were measured at full load, 25°C at 230VAC.

Output	Load	AC	Efficiency
12V	8.34A	230VAC	91%
15V	6.67A	230VAC	92%
24V	4.17A	230VAC	92%
28V	3.58A	230VAC	92%
36V	2.78A	230VAC	91%
48V	2.09A	230VAC	91%

Table 5-1 XL100 Series Output Currents at Rated Efficiency

6. Signals

6.1 Power Supply Timing

The maximum period for the output to rise to the regulated output voltage (99% of nominal voltage) from the time that AC input is applied is 1 second.

6.2 Voltage Hold-Up Time

The power supply will maintain output regulation for 22ms despite a loss of input power, when operating at full load and 115VAC input.

7. Ordering Information

The following table provides the N2Power part numbers that should appear on your purchase order and will appear on any N2Power correspondence:

MODEL	PART NUMBER	OUTPUT VOLTAGE	MODEL	PART NUMBER	OUTPUT VOLTAGE
XLO100-12	400575-01-5	12	XLO100-28	400575-04-9	28
XLU100-12	400576-01-3		XLU100-28	400576-04-7	
XLE100-12	400577-01-1		XLE100-28	400577-04-5	
XLD100-12	400578-01-9		XLD100-28	400578-04-3	
XLO100-12B	400575-07-2		XLO100-28B	400575-10-6	
XLU100-12B	400576-07-0		XLU100-28B	400576-10-4	
XLE100-12B	400577-07-8		XLE100-28B	400577-10-2	
XLD100-12B	400578-07-6		XLD100-28B	400578-10-0	
XLO100-15	400575-02-3	15	XLO100-36	400575-05-6	36
XLU100-15	400576-02-1		XLU100-36	400576-05-4	
XLE100-15	400577-02-9		XLE100-36	400577-05-2	
XLD100-15	400578-02-7		XLD100-36	400578-05-0	
XLO100-15B	400575-08-0		XLO100-36B	400575-11-4	
XLU100-15B	400576-08-8		XLU100-36B	400576-11-2	
XLE100-15B	400577-08-6		XLE100-36B	400577-11-0	
XLD100-15B	400578-08-4		XLD100-36B	400578-11-8	
XLO100-24	400575-03-1	24	XLO100-48	400575-06-4	48
XLU100-24	400576-03-9		XLU100-48	400576-06-2	
XLE100-24	400577-03-7		XLE100-48	400577-06-0	
XLD100-24	400578-03-5		XLD100-48	400578-06-8	
XLO100-24B	400575-09-8		XLO100-48B	400575-12-2	
XLU100-24B	400576-09-6		XLU100-48B	400576-12-0	
XLE100-24B	400577-09-4		XLE100-48B	400577-12-8	
XLD100-24B	400578-09-2		XLD100-48B	400578-12-6	

XLO models are Open Frame, XLU models are U-Frame, XLE models are Enclosed and XLD models are DIN Rail.
Model No. suffix: B = Class II protection; Blank = Class I protection

Table 7-1 XL100 Series Part Numbers

All XL Series power supplies are RoHS compliant For warranty information refer to www.n2power.com. Direct all questions, orders or requests for quotation as follows:

N2Power Order Desk:	orders@n2power.com	805-583-7744 x112
Fax:		805-978-5212
Sales:	sales@n2power.com	805-583-7744 x122
Technical Support	techsupport@n2power.com	805-583-7744 x119
Address	1267 Flynn Road Camarillo, CA 93012	