



Product Specification

**XL270 Series**  
**270-Watt AC to DC**  
**Power Supplies**

Document No. 706601 Rev 07-01-19

## Notices

*N2Power* is a wholly owned subsidiary of Qualstar Corporation.

*N2Power* and the *N2Power* logo are registered trademarks of Qualstar Corporation.

Copyright© 2017 by Qualstar Corporation — All Rights Reserved

For warranty information refer to <http://www.qualstar.com/n2p-pss.php>

Information contained in this document is copyrighted by Qualstar Corporation and is intended for use by customers and prospective customers to evaluate and integrate our power supplies. Customers and prospective customers may reproduce this document as needed for these purposes. Reproduction in whole or in part for any other purpose or by any other party is prohibited without prior written permission from Qualstar Corporation.

Every effort has been made to keep the information contained in this document current and accurate as of the date of publication or revision. However, no guarantee is given or implied that the document is error-free or that it is accurate with regard to any specification.

*N2Power* reserves the right to modify the design or specification without notice. This specification may not be construed as a contractual obligation except as specifically agreed to by *N2Power* in writing at the time of order.

For information about this product specification, please write or call *N2Power* at:

### **N2Power**

A Subsidiary of Qualstar Corp.  
1267 Flynn Road  
Camarillo, CA 93012

FAX: (805) 978-5212  
Phone: (805) 583-7744

E-Mail: [sales@n2power.com](mailto:sales@n2power.com)  
[www.qualstar.com/n2p-pss.php](http://www.qualstar.com/n2p-pss.php)

# Table of Contents

---

---

<b>1. Introduction</b> .....	<b>1-1</b>
1.1 Introduction.....	1-1
1.2 Agency Compliance.....	1-2
<b>2. AC Input</b> .....	<b>2-1</b>
2.1 Input Line Requirements.....	2-1
2.2 Input Over Current Protection.....	2-1
2.3 Inrush Current Limiting.....	2-1
2.4 Low Input Voltage.....	2-1
2.5 Touch Current.....	2-2
2.6 Power Factor.....	2-2
2.7 Safety Warning.....	2-3
<b>3. DC Output</b> .....	<b>3-1</b>
3.1 Output Voltage Regulation.....	3-1
3.2 Common Return.....	3-1
3.3 No Load Operation.....	3-1
3.4 Overshoot at Turn On/Turn Off.....	3-1
3.5 Output Current/Power.....	3-2
3.6 Efficiency.....	3-2
3.7 Unloaded Power Consumption.....	3-3
3.8 Cooling.....	3-3
3.9 Output Ripple/Noise.....	3-4
3.10 Local and Remote Sensing (RS).....	3-5
3.11 Parallel Operation.....	3-6
3.12 Power Supply Protection.....	3-8
3.13 Output Transients.....	3-9
3.14 Capacitive Loading.....	3-10
<b>4. General Specifications</b> .....	<b>4-1</b>
4.1 Environmental.....	4-1
4.2 Mean Time Between Failures.....	4-1
4.3 Component Stress.....	4-1
4.4 Labeling/Marking.....	4-2
4.5 Physical Dimensions.....	4-2
4.6 Weight.....	4-3
4.7 Mating Connectors.....	4-3
4.8 Signal Descriptions and Remarks.....	4-6

<b>5.</b>	<b>Timing and Control</b> .....	<b>5-1</b>
5.1	Power Supply Timing.....	5-1
5.2	Power Good Output.....	5-1
5.3	Remote Enable Input.....	5-2
5.4	Hold-Up Time.....	5-2
5.5	Output Rise Time.....	5-2
5.6	LED Indicators.....	5-2
<b>6.</b>	<b>Ordering Information</b> .....	<b>6-1</b>

# 1.

# Introduction

## 1.1 Introduction

This specification defines the design and performance characteristics of an open frame, single-phase (3 wire) universal input, power factor corrected 270-Watt switch-mode power supply. The XL270 models are listed in Table 3-1 and they provide DC power at 12V, 24V, 30V, 48V or 56V. The power supplies deliver 140W without airflow. It is the high efficiency of these supplies that enable them to be packaged in their 2" x 4" x 1.3" form factor. They all have universal AC inputs for operation from 90VAC to 264VAC and active power-factor correction to minimize RMS input currents.

All models provide a 5V standby output (5VSB, 1 Amp max.) when AC power is applied. The main output (VOUT) and 12V auxiliary (12VAUX, 0.5 Amp max.) outputs are enabled by “grounding” the Remote Enable input. The 12VAUX may be configured (optional) to remain on whenever AC power is applied. These single-output models can be used as stand-alone power supplies or for CS (Current Share) models, they can be used in redundant or N+1 configuration with up to 4 units connected in parallel. These power supplies have a built-in output OR-ing MOSFET – see Section 3.11 for details. The 12VAUX and 5VSB outputs can be connected together with other XL270's to provide redundancy, but the combined output currents are limited to the single-supply rating (i.e. 0.5 Amp and 1.0 Amp respectively).

An optional PMBus digital communications interface is also available for CS (Current Share) models to allow up to four XL270s to communicate over the same PMBus. This communications interface allows routine remote control of the main and the 12V Auxiliary outputs. The host can also query the power supply's output voltage and current as well as the transformer temperature. It can also check for a fan failure (lost tachometer pulses). A PMBus User's Guide (Document number: 706679) is available at: <https://www.qualstar.com/n2p-prod-specs.php>



## 1.2 Agency Compliance

The XL270 complies with the following international agency standards:





<b>Safety</b>	<b>Complies with Standard</b>	<b>Remarks</b>	
United States	UL 60950-1 Second Edition UL 62368-1 Second Edition (Information Technology Equipment)	Touch Current – see table 2-2 Hi-pot – 2121vdc for 1 second (Primary to Secondary and P.E.)	
Canada	CSA 22.2: 60950-1		
EU Council	2006/95/EC	Low Voltage Directive	
International	IEC 60950-1 (2005) Second Edition IEC 62368-1 (2014) Second Edition		
<b>EMC</b>	<b>Complies with Standard</b>	<b>Remarks</b>	
United States	FCC part 15, subpart B	Conducted emissions Limits per CISPR 32 Class A Tested to ANSI C63.4: 2003	
EU Council	2004/108/EC	EMC Directive	
International	EN 61204-3 (refers to the following) EN 55032 Class A  EN 61000 (refers to the following) EN 61000-3-2 Class D  EN 61000-3-3 EN 61000-4-3 EN 61000-4-4 EN 61000-4-5 EN 61000-4-6 EN 61000-4-11	Low Voltage Power Supplies – DC Output Conducted emissions Limits per CISPR 32 Class A Immunity Harmonic Current Emissions (Power Factor Correction – PFC) Voltage Fluctuations & Flicker Radiated Susceptibility Fast Transient/Burst Immunity Power Mains Surge Immunity RF Immunity Voltage Dips, Short Interruptions	
<b>Reduction of Hazardous Substances (RoHS)</b>		<b>Complies with Standard</b>	<b>Remarks</b>
EU Council		2002/95/EC 2011/65/EU	RoHS Directive RoHS 2 Directive
<b>Marks of Conformance</b>			
United States & Canada		 (Underwriters Laboratories File E211115)	
EU Council			
RoHS		 	

Table 1-1 Agency Compliance

# 2.

# AC Input

## 2.1 Input Line Requirements

The following table defines the voltage and frequency requirements for the AC line inputs to the XL270 power supply. The XL270 is capable of supplying full rated power in continuous operation throughout the specified ranges of voltages and frequencies. The power supply will automatically recover from AC power loss and is capable of starting under maximum load at the minimum AC input voltage described below.

Parameter	Minimum	Rated	Maximum
RMS Input Voltage	90 VAC	100 –240VAC	264 VAC
RMS Input Current	–	–	3.2 A @ 100 V 1.4 A @ 240 V
Input Frequency	47 Hz	50–60 Hz	63 Hz

Table 2-1 XL270 AC Input Parameters

## 2.2 Input Over Current Protection

The XL270 series incorporates a 6.3A primary AC line fuse for input over current protection to meet product safety requirements as outlined in Section 1.2.

## 2.3 Inrush Current Limiting

The cold-start (25° C) inrush current at 90° input phase angle (i.e. AC switch is closed at the peak of the AC sine wave input) is limited to less than 35 Amps peak for 240 VAC and 18 Amps peak for 120VAC.

Repetitive ON-OFF cycling of the AC input voltage should not damage the power supply or cause the input fuse to open as long as the AC remains off for more than two seconds.

## 2.4 Low Input Voltage

The application of an input voltage below the minimums specified in Table 2-1 shall not damage the XL270.

## 2.5 Touch Current

The current from AC Line or AC Neutral to Protective Earth varies linearly with the input voltage and frequency (Table 2-2). The touch currents (a.k.a. leakage currents) of multiple power supplies are additive. Consult the appropriate electrical safety specification for the maximum touch current permitted in your product. This current will always go to zero when a DPDT switch simultaneously disconnects both the line and neutral from the power supply. A single fault can occur when the AC power is applied to only the Neutral input terminal.

Line Voltage Frequency	Operating	Single Fault (see text)
120VAC, 60Hz	0.40 mA	0.75 mA
240VAC, 60Hz	0.80 mA	1.50 mA
240VAC, 50Hz	0.65 mA	1.25 mA

**Table 2-2 Touch Current – Single XL270**

## 2.6 Power Factor

The XL270 power factor exceeds 0.950 with loads of 135-watts (50%) or greater at both 115VAC and 230VAC input voltages. See Figure 2-1 for typical curves.

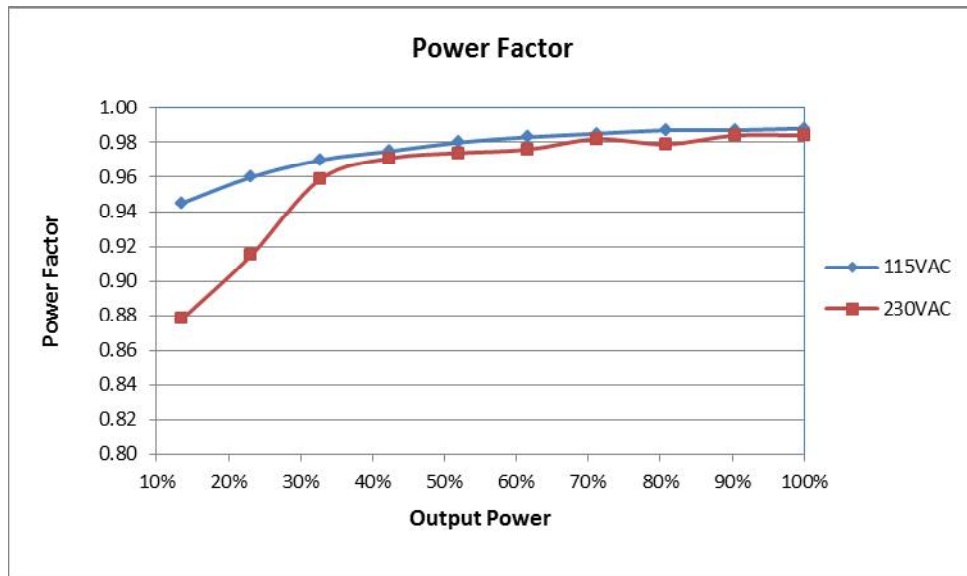

**Figure 2-1 Power Factor, Typical**



## 2.7 Safety Warning

### **WARNING**

The XL270 is a component, not a stand-alone power supply. It must be mounted inside a protective enclosure to prevent accidental shock by contact with the supply. Lethal voltages are present while AC power is applied. Allow 1-minute for storage capacitors to discharge after removing AC power before handling the XL270.

Safety and signal ground connection is via all four of the mounting holes (see Figure 4-2). All must be connected to Protective Earth. All four mounting holes must be secured by appropriate screws tightened to 5 in-lb of torque.

The user must keep any bare metal at least 2.6mm (0.10") from the AC input connector J1. An insulator can be used between J1 and adjacent bare metal to decrease this spacing.

# 3.

# DC Output

## 3.1 Output Voltage Regulation

The DC output voltages shall remain within the limits defined in Table 3-1 when measured at the power supply connector under all specified conditions contained herein. Voltage regulation is measured with load currents from zero to the rated load currents listed in Table 3-2.

Model	Output	Rated Voltage	Regulation	Minimum (VDC)	Rated (VDC)	Maximum (VDC)	Remote Sense
XL270-12	VOUT	+12 V	±3%	11.64	12.0	12.36	VOUT/RTN
XL270-24	VOUT	+24 V	±3%	23.28	24.0	24.72	VOUT/RTN
XL270-30	VOUT	+30 V	±3%	29.10	30.0	30.90	VOUT/RTN
XL270-48	VOUT	+48 V	±3%	46.56	48.0	49.44	VOUT/RTN
XL270-56	VOUT	+56 V	±3%	54.32	56.0	57.68	VOUT/RTN
All	12VAUX	+12 V	±5%	11.40	12.0	12.60	N/A
	5VSB	+5 V	±5%	4.75	5.0	5.25	N/A

Table 3-1 XL270 Output Voltage Specifications

## 3.2 Common Return

All DC outputs, status outputs and control inputs share a common return (RTN) found on all output connectors. This return floats with respect to P.E. (Protective Earth) and is by-passed with a 600V capacitor.

## 3.3 No Load Operation

A no load condition will not damage the supply or cause a hazardous condition. The power supply will remain stable and operate normally after application of a load. The Power Good logic output will indicate normal operation when the supply is unloaded.

## 3.4 Overshoot at Turn On/Turn Off

The output voltage overshoot upon the application or removal of the AC input voltage will be less than 5% above the rated voltage. No opposite polarity voltage (with respect to RTN) will be present on any output during either turn on or turn off.

### 3.5 Output Current/Power

The maximum available output power is a function of the airflow and ambient temperature. The maximum of 270-watts combined total power (from all outputs) is available with a minimum of 15-CFM of forced airflow up to a maximum ambient temperature of 50°C. Each individual output is also limited: VOUT is limited to 270-watts, 12VAUX is limited to 6W and 5VSB is limited to 5W.

Model	Output	Rated Voltage	Rated Load
XL270-12	VOUT	12 V	22.5 A
XL270-24	VOUT	24 V	11.3 A
XL270-30	VOUT	30 V	9.0 A
XL270-48	VOUT	48 V	5.7 A
XL270-56	VOUT	56 V	4.9 A
All	5VSB	5 V	1.0 A
All	12VAUX	12 V	0.5 A

Table 3-2 Maximum Individual Continuous Load Currents

### 3.6 Efficiency

The power supply efficiency varies with the output power and AC input voltage. Higher output voltage models tend to exhibit higher efficiencies due to lower currents (less IR losses). Efficiency data is measured at room temperature with 15-CFM airflow, after a 15-minute warm-up period. The measurements are taken at 10% intervals up to 100% rated output power. The 5VSB and 12VAUX outputs are unloaded. See Figure 3-1 for typical curves.

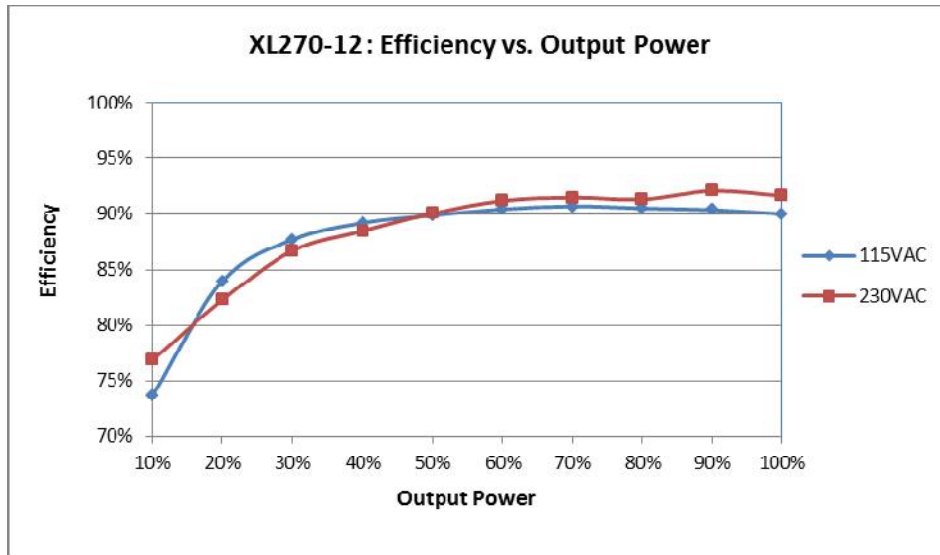

Figure 3-1 XL270-12 (12V Model) Typical Efficiency Curves

### 3.7 Unloaded Power Consumption

When unloaded with rated input voltage applied, the XL270 will consume about 3W with the power supply disabled (Remote Enable open) and about 9W under normal operation, all outputs unloaded.

### 3.8 Cooling

The XL270 can operate under Convection Cooling at temperatures up to 50°C ambient temperatures when total power output is less than 140W and the power supply is mounted open-side up. 15-CFM of airflow is required for an output power up to 270W in an ambient up to 50°C. The airflow must be either co-planar with the power supply or impinge downward in the center of the power supply from above. The XL270 may be mounted in any attitude when 15-CFM airflow is provided.

#### 3.8.1 Operation at Elevated Ambient Temperatures

In order to operate the XL270 above 50°C ambient, the output power must be linearly de-rated according the graph in Figure 3-2, up to a maximum ambient of 70°C.

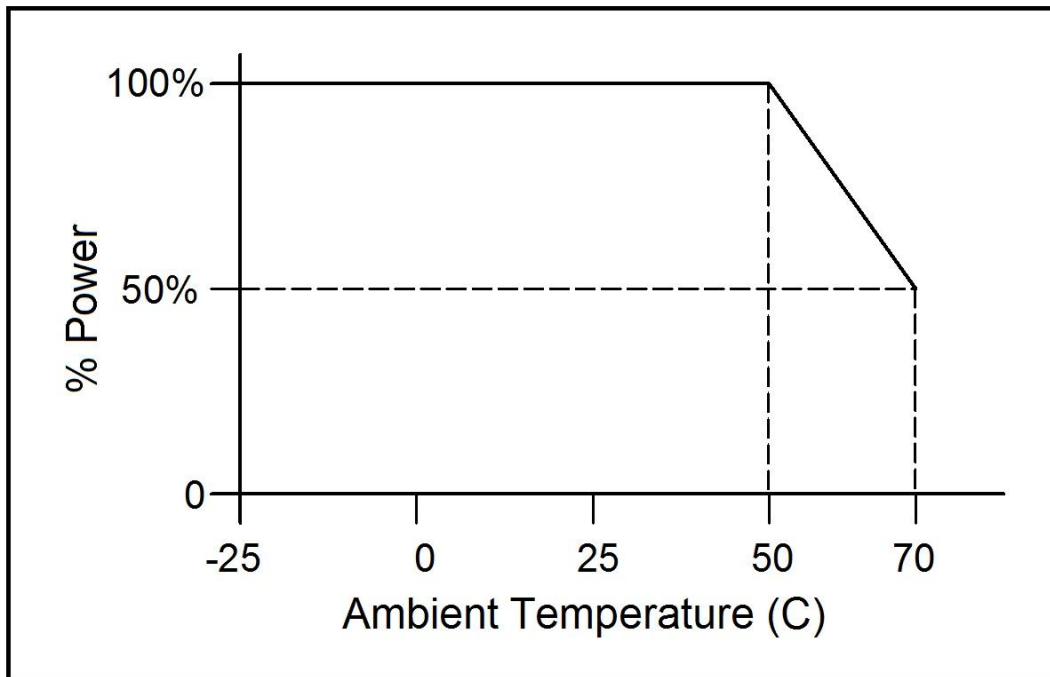

Figure 3-2 XL270 Output Power vs. Ambient Temperature. For convection, “100%” is 140W. With 15-CFM Airflow, “100%” is 270W.

### 3.8.2 Over Temperature Shutdown

The power supply is equipped with a temperature sensor for self-protection. Failure to provide adequate airflow, or operation above the specified maximum ambient, will result in the shutdown of the VOUT and 12VAUX outputs. The 5VSB output remains operational. The VOUT and 12VAUX outputs will automatically recover when the temperature of the temperature sensor sufficiently cools.

### 3.9 Output Ripple/Noise

Output ripple voltage and noise are defined as periodic or random signals over a frequency band of 10 Hz to 20 MHz. Measurements are to be made with an oscilloscope with a 20 MHz bandwidth. Outputs should be bypassed at the connector with a 0.1  $\mu$ F ceramic disk capacitor and a 47  $\mu$ F tantalum capacitor to simulate system loading (Figure 3-3). Ripple and noise (P.A.R.D.  $\equiv$  Periodic And Random Deviation) shall not exceed the limits specified in the following tables.

The ripple voltage of the output is measured at the pins of the mating connector. Ripple and noise shall not exceed the limits specified in Table 3-3 under any condition of line voltage and frequency specified in Section 2.1 and DC loading specified in Section 3.5.

Model	Output	Rated Voltage	Maximum Ripple+Noise (peak-to-peak)
XL270-12	VOUT	12 V	120 mV
XL270-24	VOUT	24 V	240 mV
XL270-30	VOUT	30 V	300 mV
XL270-48	VOUT	48 V	480 mV
XL270-56	VOUT	56 V	560 mV
All	12VAUX	12 V	120 mV
All	5VSB	5 V	50 mV

Table 3-3 Ripple + Noise Output Voltage

### 3.9.1 Ripple/Noise Test Setup

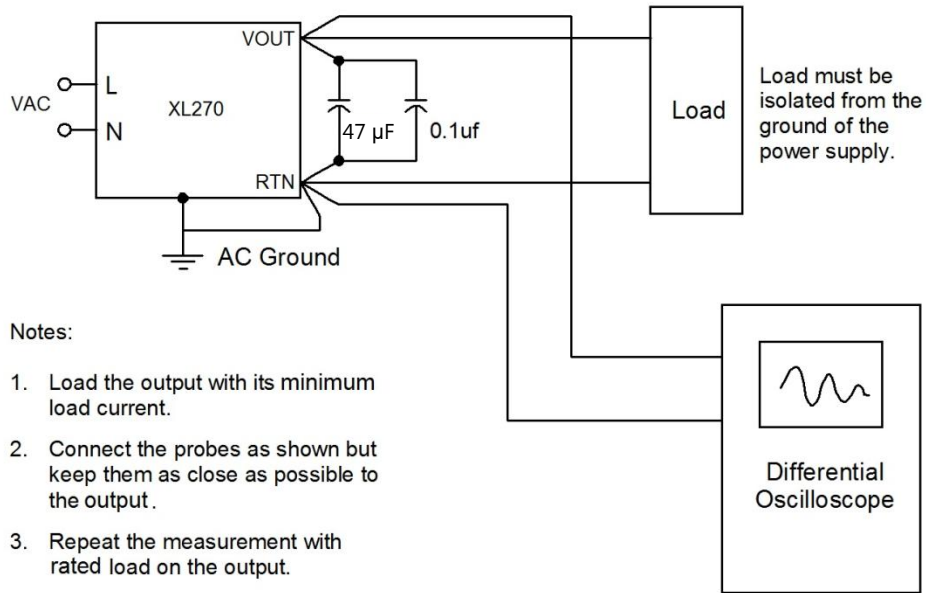

Figure 3-3 Ripple Noise Measurement Setup

### 3.10 Local and Remote Sensing (RS)

Remote sensing is provided to compensate for voltage drops in the connecting cables between VOUT / RTN and the load. The voltage droop (IR loss) between the remote sense points at the load and the remote sense inputs at the power supply will be compensated for up to 400mV. Reversing the +RS and -RS sense lines will not damage the XL270.

If the Remote Sense inputs are left open, the output voltage at the VOUT and RTN terminals will still meet the voltage regulation specification. The remote sense lines should either be connected to those terminals directly or extended through the bulkhead connectors up to the load within a user's system. Connecting the remote sense inputs lifts the voltage at the load to within the specification voltage regulation limits but will increase the VOUT voltage above the regulation limits. See Figure 3-4.

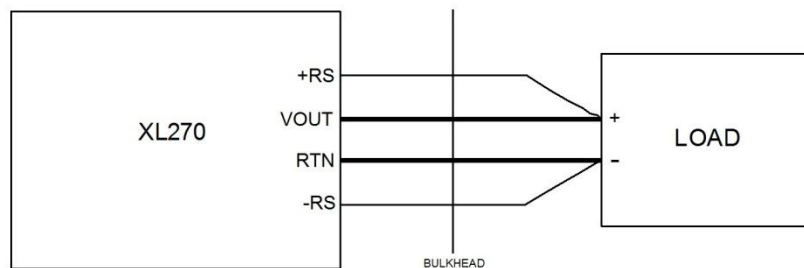

Figure 3-4 Remote Sense Wiring

### 3.11 Parallel Operation

By using the built-in active current-sharing from XL270 CS (Current Share) models, the VOUT of up to four power supplies can be connected in parallel to provide higher output power as shown in Table 3-4. They can also be used in an N+1 configuration to provide greater reliability. Remote sensing may be used in parallel operation.

Only the VOUT is capable of active current sharing. Because of inherent limitations, it is recommended that the total load not exceed 90% of the sum of the rated outputs (see Table 3-4). Current sharing accuracy drops with the total load power, thus a minimum load of 35W per power supply is recommended. The following table lists the recommended maximum output power.

Number of XL270s	N+1 Configuration
2	270 watts
3	486 watts
4	729 watts

**Table 3-4 Recommended Output Power for N+1 Configurations**

When the three or more power supplies are connected in parallel operation, at least one PG signal from the power supplies must be active before applying load. The power supplies will tolerate the dramatic load fluctuations encountered in an N+1 redundant configuration when supplies are removed and replaced.

### 3.11.1 Current Sharing Connections

For the purposes of active current sharing, communication between paralleled XL270's is made through the CAN communications interface pins on the J3 option connector (CAN ≡ Controller Area Network). The CANH (J3-8), CANL (J3-9) and RTN (J3-6) pins of each power supply must be connected together. Current sharing does not require the remote sensing, but the sharing accuracy will be enhanced with its use. See Figure 3-5 below.

Each individual PG/PF signal (J3-10) should be monitored separately by the user system.

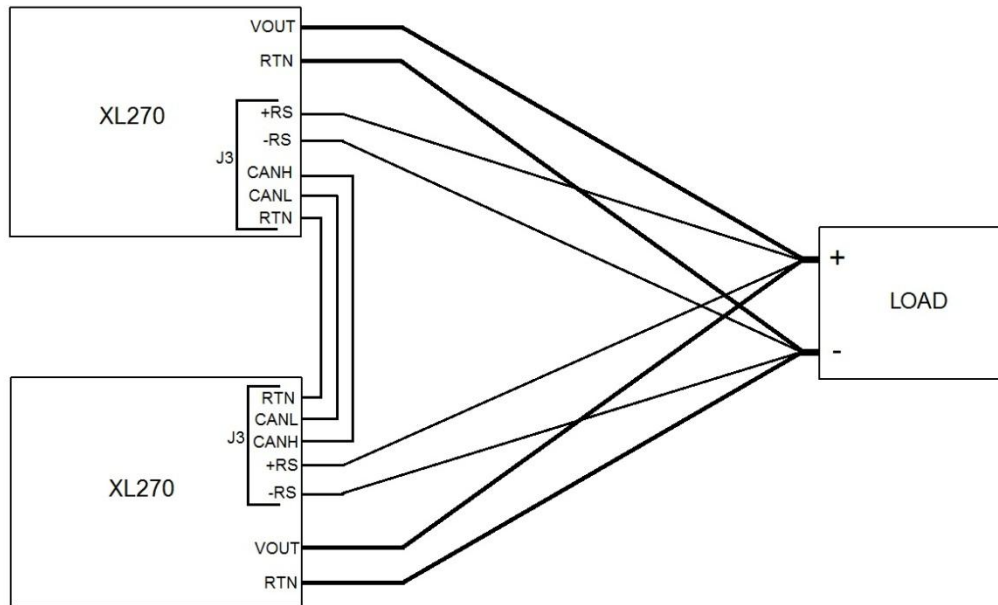

Figure 3-5 Current Share Wiring Example – Two XL270's.

### 3.11.2 Current Share Accuracy

When the CAN Bus of all paralleled units are connected together and all the Remote Sense signals are connected at the regulation point, the current delivered by any of the sharing supplies will not vary by more than  $\pm 5\%$  of IDEAL, at rated current.

Let N = Number of Units in Parallel.

$$I_{TOTAL} = I_1 + I_2 + \dots + I_N$$

$$I_{IDEAL} \equiv I_{TOTAL} \div N$$

Error =  $I_k - I_{IDEAL}$ , where  $I_k$  is the k-th unit's current

$$\%Error = [(I_k - I_{IDEAL}) \div I_{IDEAL}] \times 100\%$$

Sharing accuracy deteriorates with decreasing load current.



### **3.11.3 5V Standby Parallel Operation**

For parallel operation, each 5VSB requires a series diode (a schottky, supplied by customer, is recommended) placed between the output and the load for isolation. Configured this way, the 5VSB will remain active so long as one of the paralleled supplies is functioning. As stated before, the total current rating may not go beyond the single supply rating.

### **3.11.4 12V Auxiliary Parallel Operation**

The 12VAUX requires a series diode as described in 3.11.3.

### **3.11.5 Output Rise Times**

The output rise time and monotonic requirements of 5.5 may not be met when the paralleled units are powered up into a load that exceeds 270-watts. This is due to differing in start-up times of the paralleled power supplies.

## **3.12 Power Supply Protection**

There are several different protection circuits designed to protect the load and the XL270 from component failures and extraordinary circumstances.

### **3.12.1 Over Temperature Protection (OTP)**

If the XL270 is operated without adequate cooling, it will sense an over-temperature condition and shut down the VOUT and 12VAUX outputs. It will restart after it has cooled down to below its maximum operating temperature. The PF/PG signal and LED go false about 2ms before the V1 output is disabled. The V2 and V3 outputs are unaffected by a V1 OTP condition.

### **3.12.2 Over-Voltage Protection (OVP)**

Only VOUT provides Over-Voltage Protection. When an over-voltage occurs (nominally at 120% of rated output voltage with an acceptable range of 115% - 125%), the power supply will shut down and latch off. The AC input will need to be cycled OFF-ON for recovery.

When OVP is triggered, the 12VAUX will be disabled but the 5VSB will continue to function. The XL270 will shut down under the following over voltage conditions:

Model	VOUT	Minimum	Nominal	Maximum
XL270-12	12V	13.8V	14.4V	15.0V
XL270-24	24V	27.6V	28.8V	30.0V
XL270-30	30 V	34.5V	36.0V	37.5V
XL270-48	48V	55.2V	57.6V	60.0V
XL270-56	56V	58.0V	59.0V	60.0V

**Table 3-5 Over Voltage Protection Limits**

### 3.12.3 Over Current Protection (OCP)

An over-load on the VOUT will induce constant-current limiting which will cause the output voltage to fall. The constant-current limit has a threshold of 115% ( $\pm 5\%$ ) of the rated output current. The VOUT current-limit is not affected by the loading on 5VSB and 12VAUX.

During OCP an under-voltage detector (UVD) turns off the Power Good output signal and LED before the output voltage falls below 83% of rated and restores them to the on state before the output voltage rises above 86%.

The under-voltage protection (UVP) circuit will shut the output off when the output voltage falls below about 67%. The XL270 will attempt to restart approximately 6-seconds after the UVP event. If the load current is low enough to allow the output voltage to exceed 67%, the supply will remain on. If not, it will attempt to restart every 6 seconds.

### 3.12.4 Short Circuit Protection (SCP)

A short circuit on VOUT will disable the output but not damage the XL270. A short on the 12VAUX output will disable all outputs. The XL270 will periodically attempt to restart until the short circuit condition is removed. After successfully restarting, the power supply will operate normally.

## 3.13 Output Transients

The maximum output voltage transient caused by step load changes will not exceed the output voltage regulation limits by more than 5%. With an AC input as specified in Section 2.1, the power supply will remain stable when subjected to the load transients described below with capacitive loading per Table 3-6:

- Load changes between 75% and 100% on any output
- Load changing repetition of 50 to 333 cycles per second
- Transient load slew rate = 1 A /  $\mu$ s

### 3.14 Capacitive Loading

The XL270 will startup and operate normally with load capacitances simultaneously present on the all outputs not exceeding those listed in Table 3-6.

<b>Output</b>	<b>XL270-12</b>	<b>XL270-24</b>	<b>XL270-30</b>	<b>XL270-48</b>	<b>XL270-56</b>
VOUT (12 V)	3,900 $\mu$ F				
VOUT (24 V)		1,000 $\mu$ F			
VOUT (30 V)			620 $\mu$ F		
VOUT (48 V)				240 $\mu$ F	
VOUT (56 V)					200 $\mu$ F
12VAUX	180 $\mu$ F	180 $\mu$ F	180 $\mu$ F	180 $\mu$ F	180 $\mu$ F
5VSB	220 $\mu$ F	220 $\mu$ F	220 $\mu$ F	220 $\mu$ F	220 $\mu$ F

**Table 3-6 XL270 Maximum Capacitive Loading**

# 4.

# General Specifications

## 4.1 Environmental

The XL270 meets or exceeds the following environmental specifications:

Parameter	Conditions	Specification	Remarks
Temperature	Operating	-25°C to 70°C	See airflow and derating requirements in 3.8
	Non-Operating	-40°C to 85°C	
Relative Humidity	Operating	95% Maximum	Non-Condensing
	Non-Operating	95% Maximum	Non-Condensing
Altitude	Operating	10,000 feet MSL Max.	3048 meters
	Non-Operating	50,000 feet MSL Max.	15,240 meters
Vibration	No damage	2.4G RMS Maximum	5-500Hz, 10-min. each axis per MIL-PRF-28800F: 3.8.4.1 (Class 3,4)
Mechanical Shock	No damage	30G half-sine, 11ms	Six shocks each axis per MIL-PRF-28800F: 4.5.5.4.1

**Table 4-1 Environmental Specifications**

The XL270 will start and meet its performance specifications within the environmental conditions listed in Table 4-1. It has also been demonstrated that the XL270 will start reliably at -40°C with an input voltage of 100VAC or greater. Consult N2Power for technical details.

## 4.2 Mean Time Between Failures

The calculated MTBF of the power supply is equal to or greater than 500,000 hours of continuous operation at maximum output loading and worst case input line voltage with forced-air cooling at 25°C. N2Power does not warrant the MTBF to be representative of any particular unit. The MTBF of the power supply is calculated with an 80% confidence level in accordance with Bellcore, SR-332, Issue 2. Actual failure rates vary from unit to unit.

## 4.3 Component Stress

The XL270 was designed with the following component-derating guidelines at an operating ambient temperature of 50°C: semiconductor junction temperatures shall not exceed ninety 90 % of manufacturer's rating. Inductor winding temperatures shall not exceed safety agency requirements. Electrolytic capacitor case temperatures shall not exceed 95% of rated temperature. Resistor power dissipation shall not exceed 50% of rated while other components will not be operated at more than 90% of their rated voltage or current.

## 4.4 Labeling/Marking

The power supply is marked and labelled with the N2Power logo model number, part number, input and output specifications, production code, appropriate safety agency logos, CE mark, and country of origin. An example label is pictured below.

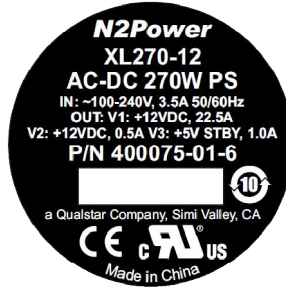

Figure 4-1 Sample XL270 Label

## 4.5 Physical Dimensions

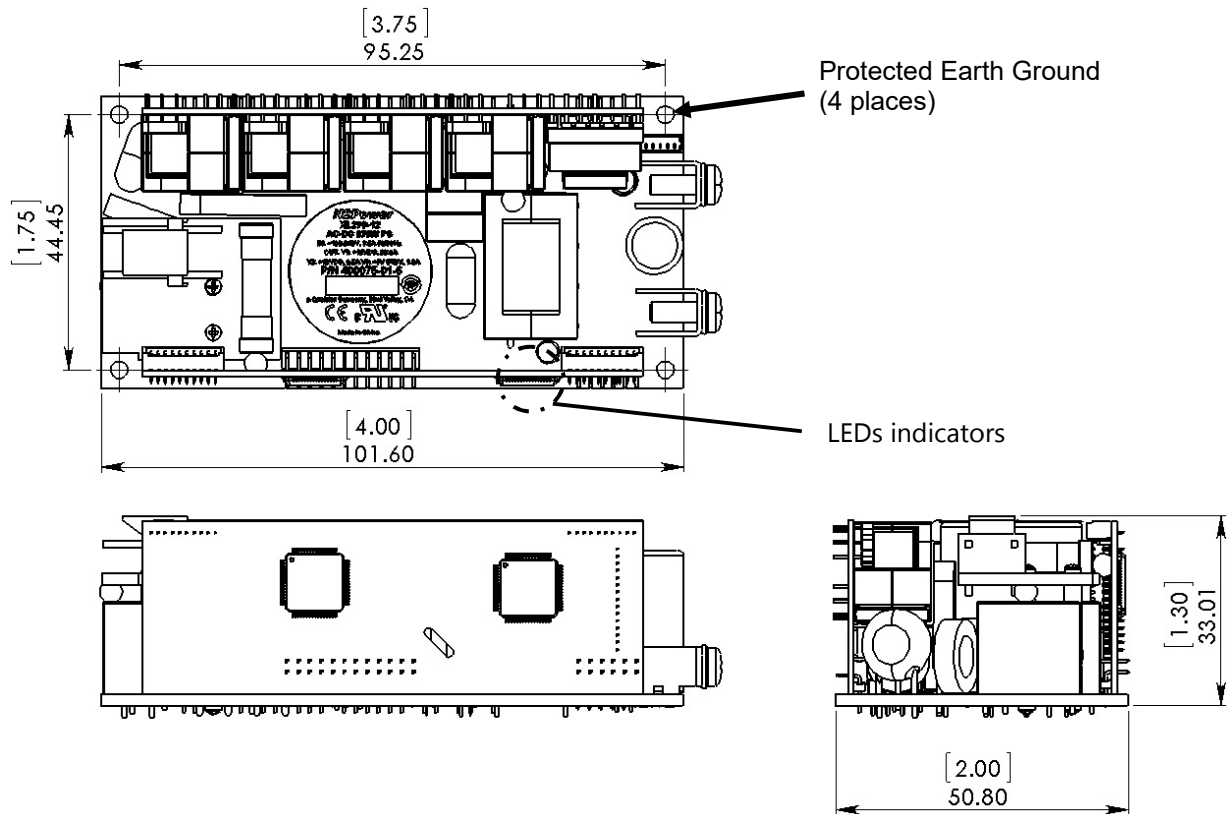

Figure 4-2 XL270 Series Dimensions

## 4.6 Weight

Units	Net Weight
Pounds	0.47
Ounces	7.5
Kilograms	0.21

Table 4-2 XL270 Weight

## 4.7 Mating Connectors

The user must furnish all mating connectors. The mating connectors must meet the requirements of all applicable safety agencies (notably UL).

Note that the female contacts that mate to the power supply are only rated for 25-30 mating cycles. Excessive mating cycles cause wear, leading to increased contact resistance and heating, further resulting in the eventual failure of the mating terminal and possibly the header itself.

### 4.7.1 AC Input Connector (J1)

The AC input connector to the XL270 is a 3-pin Molex™ (Molex is a trademark of the Molex Corporation) KK style header with 0.156" centers. The center pin is omitted to provide adequate insulation spacing. The Molex part numbers for the mating housing and crimp-style snap-in terminals are listed below. There may be equivalent connectors available from other manufacturers. A minimum of AWG 18 wire is recommended.

J1	Molex P/N
Connector Circuits (pins)	2 of 3
Mating Housing	09-50-8031
Rated Contact Current	7.0 A
Crimp Terminal (tin)	08-52-0112
Rated Wire Size	AWG 18 or 20

Table 4-3 J1 Mating Connector

### 4.7.2 Protective Earth

The XL270 must be connected to protective earth (P.E.) at all four corner mounting holes, See Figure 4-2. The four corner mounting holes provide both safety grounding and common mode by-passing of conducted EMI emissions.

### 4.7.3 Output Terminals (VOUT and RTN)

The DC output terminals for VOUT are designed to accept a ring-lug terminal. There are many sources available. A minimum of AWG 16 wire is recommended. The lugs must have a minimum I.D. of 0.140" [3.53mm] and a maximum O.D. of 0.32" [8.1mm]. The lugs must be contaminant free and should be tightened to a torque of approximately 8-inch-pounds [0.9 N-m]. These terminals use 6-32 UNC screws.

### 4.7.4 Option Connector (J3)

The J3 connector is a Molex Pico-Blade header (a.k.a. a jack) with 1.25mm pin spacing. The Molex part numbers for the mating housing and crimp-style snap-in terminals are listed in Table 4-4. There may be equivalent connector components available from other manufacturers.

J3	Molex P/N
Number of Circuits (pins)	15
Mating Housing (white)	51021-1500
Crimp Terminal	50212-8100
Rated Contact Current	2 A
Rated Wire Size	AWG 30 thru 24

Table 4-4 J3 Mating Connectors

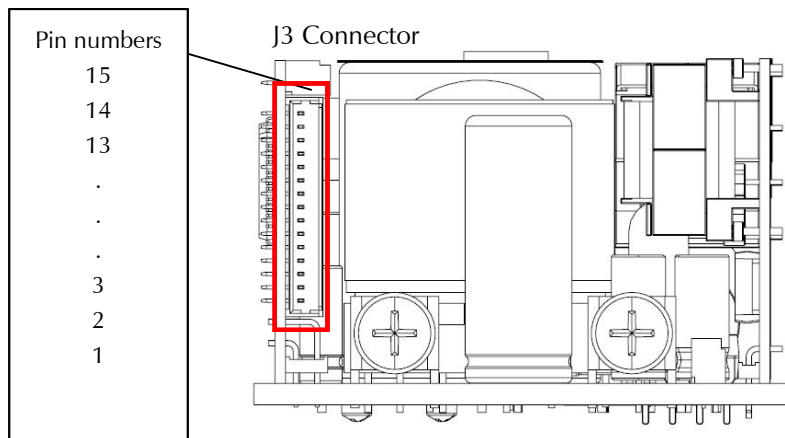

Figure 4-3 J3 Connector

#### 4.7.5 Auxiliary/Standby Output Connector (J6)

The J6 connector is a Molex Micro-Latch header (a.k.a. a jack) with 2mm pin spacing. The Molex part numbers for the mating housing and crimp-style snap-in terminals are listed in Table 4-4. There may be equivalent connector components available from other manufacturers.

J6	Molex P/N
Number of Circuits (pins)	5
Mating Housing (white)	51065-0500
Crimp Terminal	50212-8100
Rated Contact Current	2 A
Rated Wire Size	AWG 30 thru 24

Table 4-5 J6 Mating Connectors

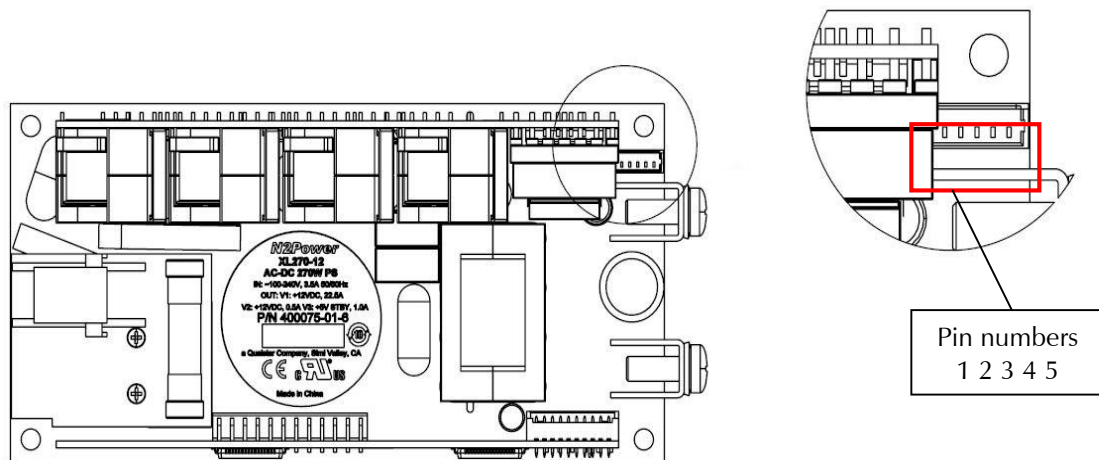

Figure 4-4 J6 Connector



## 4.8 Signal Descriptions and Remarks

Signal	Description/Remarks
AC Line (L1)	Highest in potential compared to earth ground. Should be connected to the AC power switch.
AC Neutral (L2)	Closest in potential to earth ground. Should not be connected to a single-pole power switch.
RTN / DC Return (ground)	XL270 circuit return for all outputs and status/control signals.
VOUT	The main output (+)
I <sup>2</sup> C Serial Clock	Optional: Provides PMBus control/status interface. Pulled-up to 3.3V by a 4.7K resistor. Maximum frequency is 100Khz.
I <sup>2</sup> C Serial Data	Optional: Provides PMBus control/status interface. Pulled-up to 3.3V by a 4.7K resistor.
Address 1	High-true address selection input (2 bits: 0,1).
Address 0	High-true address selection input (2 bits: 0,1).
CAN HIGH	HIGH data line for CAN (Controller area Network) communications (for current sharing and service use)
CAN LOW	LOW data line for CAN (Controller area Network) communications (for current sharing and service use)
-RS	Remote sense for RTN
+RS	Remote sense for VOUT (compensates for load-cable drop)
PF/PG	A high-logic level ( $\approx 4.5V$ ) indicates the output power is in regulation for at least the next 2ms.
RE	Remote Enable Input
12V Auxiliary (12VAUX) / FAN Controlled Output	Provides 0.5A at 12V. Uses RTN for its return. With the PMBus command, this output can switch on and off with a preprogrammed duty cycle to control fan speed.
5VSB	Provides 1A at 5V. Uses RTN for its return.
Tachometer Input	The tachometer output of a single fan may be connected to this input. The loss of the tachometer signal is detected and can be reported over the optional serial data interface.

**Table 4-6 Signal Descriptions and Remarks**

<b>Pin</b>	<b>Signal Name</b>
J1-1	VAC Neutral Input (L2)
J1-2	No Pin (open)
J1-3	VAC Line Input (L1)
<b>Pin</b>	<b>Signal Name</b>
J2-1,J2-2	Jumper for Gateway application
<b>Pin</b>	<b>Signal Name</b>
N/A	VOOUT (Positive with respect to RTN)
N/A	RTN (Main Output Return)
<b>Pin</b>	<b>Signal Name</b>
J3-1	I <sup>2</sup> C Serial Clock
J3-2	I <sup>2</sup> C Serial Data
J3-3	Address 1 Input (A0, see below)
J3-4	Address 0 Input (A1, see below)
J3-5	Return (RTN)
J3-6	Return (RTN)
J3-7	CAN High (CANH) (for Current Sharing)
J3-8	CAN High (CANH) (for Current Sharing)
J3-9	CAN Low (CANL) (for Current Sharing)
J3-10	CAN Low (CANL) (for Current Sharing)
J3-11	Negative Remote Sense (-RS)
J3-12	Positive Remote Sense (+RS)
J3-13	Power Fail/Power Good (PF/PG)
J3-14	Remote Enable (ENABLE)
J3-15	Not used
<b>Pin</b>	<b>Signal Name</b>
J6-1	Return (RTN)
J6-2	5V Standby (5VSB)
J6-3	Return (RTN)
J6-4	12V Auxiliary (12VAUX) / FAN Controlled Output
J6-5	Tachometer Input

**Table 4-7 Connector Pin Assignments**

# 5.

# Timing and Control

## 5.1 Power Supply Timing

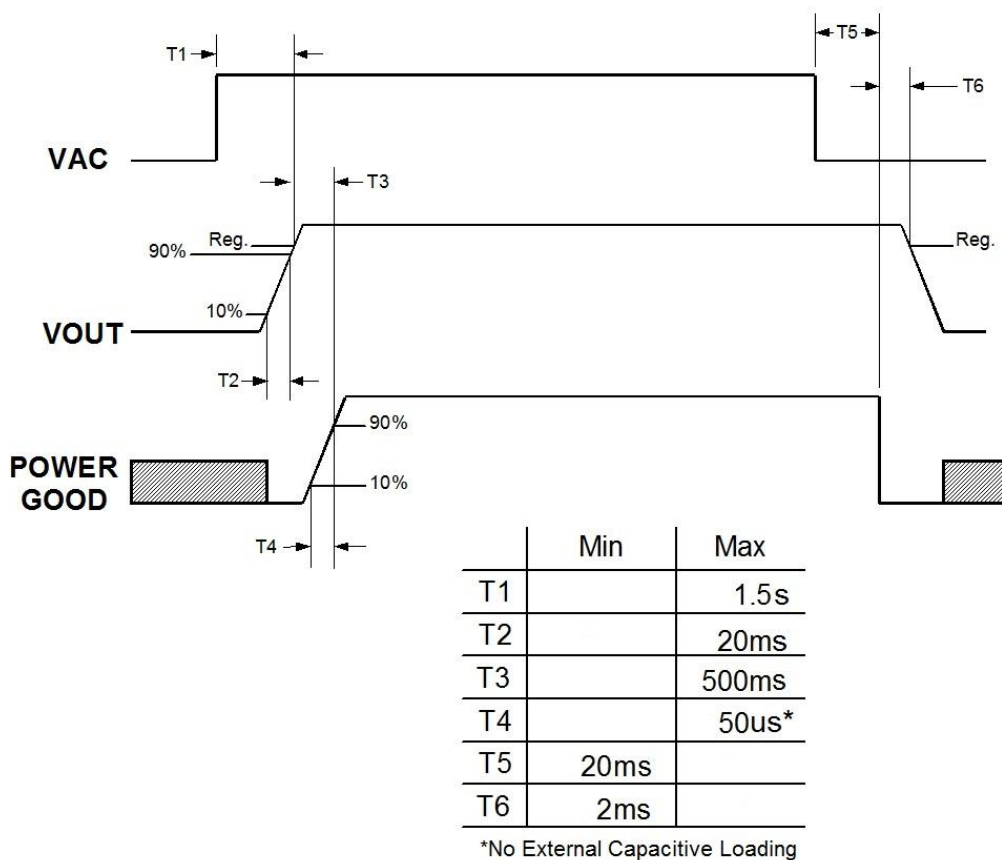

Figure 5-1 XL270 Timing Diagram

## 5.2 Power Good Output

The Power Good signal provides a logic HIGH level to indicate VOUT is within its regulation limits and that sufficient mains energy is stored by the power supply to ensure continuous power operation within specification for the minimum hold-up time. When the AC mains power is removed for a period longer than 20ms, the Power Good signal transitions to a logic LOW level. The Power Good signal (CMOS output) is capable of sinking and sourcing 4mA from an internal 5.0V pull-up.

### **5.3 Remote Enable Input**

This input is normally floating to enable VOUT. It must be connected to RTN to disable VOUT. It has no effect on the 5V stand-by, or the 12V auxiliary. It is internally pulled-up to 3.3V through a 10k $\Omega$  resistor. External voltage may be applied to this input to control VOUT. The input voltage must be less than 0.2V in order to disable VOUT and greater than 2.0V (up to 3.3V) to enable it.

### **5.4 Hold-Up Time**

The power supply will maintain output regulation per Table 3-1 despite a loss of input power at 100VAC/50Hz and 230VAC/50Hz at maximum rated continuous output for a minimum of 22ms.

### **5.5 Output Rise Time**

All outputs from the XL270 shall rise monotonically from 10% to 90% of their rated output voltage (Table 3 1) within 0.2ms to 20ms under any loading conditions (Table 3-2). The voltage rise of two or more XL270s operating in parallel may not be monotonic.

### **5.6 LED Indicators**

There are two LED indicators mounted near the top of the control board behind J5 (See Figure 4-2). A green LED illuminates whenever the Power Good signal is true (high). This indicates the main output is on and regulating. A red LED indicates a problem with the unit.

# 6.

# Ordering Information

The following table provides the N2Power part numbers that should appear on your purchase order and will appear on any N2Power correspondence:

<b>Model Number</b>	<b>V1</b>	<b>XL270 N2Power Part Number</b>
XL270-12	12 V	400075-01-6
XL270-24	24 V	400075-02-4
XL270-30	30 V	400075-03-3
XL270-48	48 V	400075-05-7
XL270-56	56 V	400075-07-3
XL270-12 CS	12 V	400075-09-9
XL270-24 CS	24 V	400075-10-7
XL270-30 CS	30 V	400075-11-5
XL270-48 CS	48 V	400075-13-1
XL270-56 CS	56 V	400075-15-6

**Table 6-1 XL270 Part Numbers**

For warranty information refer to <http://www.qualstar.com/n2p-pss.php>

All XL270 power supplies are RoHS compliant.

Direct all questions, orders or requests for quotation as follows:

N2Power Order Desk:	<a href="mailto:orders@n2power.com">orders@n2power.com</a> 805-583-7744 x112
Fax (Attention N2Power):	805-978-5212
Sales:	<a href="mailto:sales@n2power.com">sales@n2power.com</a> 805-583-7744 x122
Technical Support	<a href="mailto:techsupport@n2power.com">techsupport@n2power.com</a> 805-583-7744 x119
Street Address:	1267 Flynn Road Camarillo, CA 93012