

<b>DRAWING NUMBER:</b>	<b>09-9072-1-XXXX</b>
<b>PRODUCT GROUP:</b>	PANEL JACKS AND TERMINALS
<b>SUB-GROUP:</b>	PANEL JACKS AND TERMINALS - THREAD MOUNT
<b>DESCRIPTION:</b>	PANEL JACK - METAL THREAD

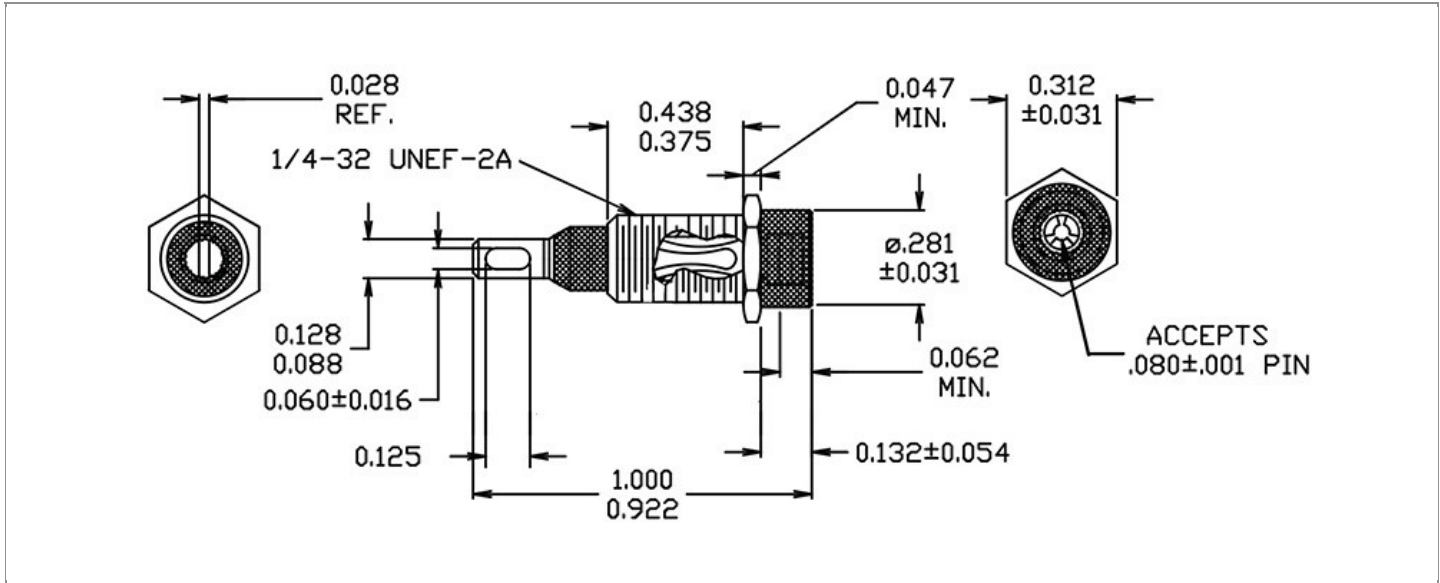

ACCEPTS PIN / PLUG / JACK SIZE	MIN. HOLE DEPTH	MOUNTING ORIENTATION	BOARD / PANEL MOUNTING METHOD
0.080" ± 0.001	0.420"	VERTICAL	THREAD MOUNT (1/4-32 NUT)
MOUNTING HOLE SIZE	BOARD / PANEL THICKNESS	FEED THRU COMBINATION	OVERALL LENGTH
0.257" ± 0.002	UP TO 3/16"	JACK/EYELET	0.922"

**PART NO. STRUCTURE:**

<b>09-9072</b>	<b>-</b>	<b>1</b>	<b>-</b>	<b>XX</b>	<b>XX</b>
PART SERIES		DIMENSION		FINISH	INSULATION COLOR

**MATERIAL OPTIONS:**

**09-9072-1-XXXX**

COMPONENT	MATERIAL	MATERIAL AND SPECIFICATION
<b>BODY</b>	BRASS	BRASS PER ASTM B16, ALLOY C36000, 1/2 HARD
<b>SPRING (CAGE)</b>	BERYLLIUM COPPER	BERYLLIUM COPPER PER ASTM B194, ALLOY C17200
<b>INSULATION*</b>	NYLON	NYLON PER ASTM D4066
<b>BASE/METAL SLEEVE</b>	BRASS	BRASS PER ASTM B16, ALLOY C36000, 1/2 HARD
<b>NUT</b>	BRASS	BRASS PER ASTM B16, ALLOY C36000, 1/2 HARD
<b>WASHER</b>	PHOSPHOR BRONZE	PHOSPHOR BRONZE PER ASTM B139/B103, ALLOY C51000
<b>LUG</b>	N/A	N/A

\*For Insulation color, please see INSULATION COLOR OPTIONS on Page 2

FINISH - PLATING OPTIONS:

09-9072-1-XXXX

FINISH CODE	COMPONENT	FINISH	FINISH AND SPECIFICATION
03	BODY	GOLD	0.000010"MIN. GOLD PER ASTM B488, TYPE II, CODE C OVER 0.000100"MIN. NICKEL PER SAE-AMS-QQ-N-290, CLASS 2
	SPRING (CAGE)	GOLD	0.000030"MIN. GOLD PER ASTM B488, TYPE II, CODE C OVER 0.000100"MIN. NICKEL PER SAE-AMS-QQ-N-290, CLASS 2
	BASE/METAL SLEEVE	NICKEL	0.000100"MIN. NICKEL PER SAE-AMS-QQ-N-290, CLASS 2
	NUT	NICKEL	0.000100"MIN. NICKEL PER SAE-AMS-QQ-N-290, CLASS 2
	WASHER	NICKEL	0.000100"MIN. NICKEL PER SAE-AMS-QQ-N-290, CLASS 2
	LUG	N/A	N/A
035	BODY	GOLD	0.000020"MIN. GOLD PER ASTM B488, TYPE II, CODE C OVER 0.000030"-0.000150" NICKEL PER SAE-AMS-QQ-N-290, CLASS 2
	SPRING (CAGE)	GOLD	0.000050"MIN. GOLD PER ASTM B488, TYPE II, CODE C OVER 0.000030"-0.000150" NICKEL PER SAE-AMS-QQ-N-290, CLASS 2
	BASE/METAL SLEEVE	NICKEL	0.000200"MIN. NICKEL PER SAE-AMS-QQ-N-290, CLASS 1
	NUT	NICKEL	0.000200"MIN. NICKEL PER SAE-AMS-QQ-N-290, CLASS 1
	WASHER	NICKEL	0.000200"MIN. NICKEL PER SAE-AMS-QQ-N-290, CLASS 1
	LUG	N/A	N/A

INSULATION COLOR OPTIONS:

09-9072-1-XXXX

INSULATION COLOR	BLACK	BROWN	RED	ORANGE	YELLOW	GREEN	BLUE	VIOLET	GRAY	WHITE
COLOR CODE NO.	10	11	12	13	14	15	16	17	18	19

TOLERANCES:\*

DECIMAL	FRACTIONAL	ANGULAR	DRAWING ORIGATION DATE	LAST MODIFICATION DATE
± 0.010	± 1/64	N/A	5/2/1996	1/1/2017

\*All dimensions are in inches.

RoHS COMPLIANCE:

09-9072-1-03XX

PART NUMBER	RoHS COMPLIANT
09-9072-1-0310	YES
09-9072-1-0311	YES
09-9072-1-0312	YES
09-9072-1-0313	YES
09-9072-1-0314	YES
09-9072-1-0315	YES
09-9072-1-0316	YES
09-9072-1-0317	YES
09-9072-1-0318	YES
09-9072-1-0319	YES

09-9072-1-035XX

PART NUMBER	RoHS COMPLIANT
09-9072-1-03510	YES
09-9072-1-03511	YES
09-9072-1-03512	YES
09-9072-1-03513	YES
09-9072-1-03514	YES
09-9072-1-03515	YES
09-9072-1-03516	YES
09-9072-1-03517	YES
09-9072-1-03518	YES
09-9072-1-03519	YES

MILITARY REFERENCE SPECIFICATIONS:

09-9072-1-03XX

PART NUMBER	MIL SPECIFICATION	MIL PART NUMBER
09-9072-1-0310	N/A	N/A
09-9072-1-0311	N/A	N/A
09-9072-1-0312	N/A	N/A
09-9072-1-0313	N/A	N/A
09-9072-1-0314	N/A	N/A
09-9072-1-0315	N/A	N/A
09-9072-1-0316	N/A	N/A
09-9072-1-0317	N/A	N/A
09-9072-1-0318	N/A	N/A
09-9072-1-0319	N/A	N/A

09-9072-1-035XX

PART NUMBER	MIL SPECIFICATION	MIL PART NUMBER
09-9072-1-03510	MIL-DTL-39024/10	M39024/10-13G (MS16108-3C)
09-9072-1-03511	MIL-DTL-39024/10	M39024/10-14G (MS16108-4C)
09-9072-1-03512	MIL-DTL-39024/10	M39024/10-12G (MS16108-2C)
09-9072-1-03513	MIL-DTL-39024/10	M39024/10-16G (MS16108-6C)

Continued on next page...

MILITARY REFERENCE SPECIFICATIONS CONTINUED:

09-9072-1-035XX

PART NUMBER	MIL SPECIFICATION	MIL PART NUMBER
09-9072-1-03514	MIL-DTL-39024/10	M39024/10-18G (MS16108-8C)
09-9072-1-03515	MIL-DTL-39024/10	M39024/10-15G (MS16108-5C)
09-9072-1-03516	MIL-DTL-39024/10	M39024/10-17G (MS16108-7C)
09-9072-1-03517	MIL-DTL-39024/10	M39024/10-20G (MS16108-10C)
09-9072-1-03518	MIL-DTL-39024/10	M39024/10-19G (MS16108-9C)
09-9072-1-03519	MIL-DTL-39024/10	M39024/10-11G (MS16108-1C)

NOTES:

**DATASHEET NOTES**

FOR PART NO. WITH FINISH "03": NUT PART NO.: 701-7414-02, WASHER PART NO.: 701-7705-02; FOR PART NO. WITH FINISH "035": NUT PART NO.: 701-7414-022, WASHER PART NO.: 701-7705-022.

**INSTRUCTION NOTES**

SUPPLIED WITH NICKEL PLATED BRASS HEX NUT (1/4-32 x 11/32" x 3/32") AND NICKEL PLATED PHOSPHOR BRONZE 1/4 INTERNAL TOOTH LOCKWASHER.